

Equipment 2023

US Edition



**MOUNTAIN**  
EQUIPMENT







John Crook,  
Koyo Zam, Pakistan.  
Photography by Uisdean Hawthorn



# Proven, protective and precise

In a world of increasing complexity, Alpinism is meaningful simplicity.

A life lived in the pursuit of raw experiences in the mountains, within the fellowship of Alpinism, is a focused yet deeply rewarding existence.

More than the physical act of moving and climbing, Alpinism is a deep connection to yourself, the decisions you make, the respect you have for others and the reverence you feel for our steep and wild natural world.

Alpinists share more than route ticks and summit objectives, we share a dedication to a life lived just outside what most would consider the normal. Not just a mere sport, Alpinism is a culture. A way of life; our way of life.

Mountain Equipment lives at the heart of the culture of Alpinism, we understand the nuanced needs of those who live their lives in the Alpinist way. The clothing and equipment we create is born from deep experience. Proven, protective and precise, our designs enable every Alpinist climbing, living and working to make their own mark on our culture.

---

This workbook contains all products that are available for sale from March 1<sup>st</sup> 2023 through to January 31<sup>st</sup> 2024.

We take great care to ensure all information is correct at time of going to press. As always, specifications may occasionally be subject to change. All weights quoted are for size L or size 12 unless otherwise stated and are rounded to the nearest 5g. Please note that due to manufacturing tolerances actual weights may differ slightly from those stated.



A photograph of two mountaineers in orange sleeping bags on a rocky mountain peak at dawn. The scene is set against a backdrop of a vast, snow-covered mountain range under a clear sky. The lighting is soft and warm, highlighting the texture of the sleeping bags and the ruggedness of the rock.

# Contents

---

# Equipment 2023

---

## US Edition

Sustainability	06
Packs	08
Sleeping Mats	16
Sleeping Bags	26
Kit Bags & Accessories	46
Fits	50
Technical Data	52
Our Guarantees	56
Sales Agents	60



Natalie Berry,  
Magic Wood, Switzerland.  
Photography by Chris Prescott

# Sustainability

---





P

### **PFC-Free**

Our products are defined as being fluorocarbon-free when no PFC's have been used in the manufacture of a product's major fabrics.

Components e.g. zips are excluded. Unfortunately, because PFC's are now so widely dispersed in the environment it is impossible to eradicate traces of PFC's entirely and some level of contamination cannot be avoided.

R1

### **100% Recycled**

We define a product as 100% recycled when 100% of a product's major fabrics and fill (if applicable) is composed overall from recycled content. Components e.g. zips and minor trim e.g. interlinings are excluded.

O

### **Organic Cotton**

For a product to be labelled as using Organic Cotton, 100% of all the cotton used must be from an Organic source. Minor components and trim are excluded.

DC

### **DOWN CODEX® Audited Source**

A down product is defined as causing no unnecessary harm and coming from an ethical and traceable source when 100% of the down used comes from a DOWN CODEX® audited source.

R.5

### **50% Recycled**

We define a product as 50% recycled when at least 50% of a product's major fabrics and fill (if applicable) is composed overall from recycled content.

Components e.g zips and minor trim e.g. interlinings are excluded.

FW

### **Fair Wear On-Site Inspection**

As a company Mountain Equipment actively monitors in excess of 90% of its production facilities. We define an individual product as having been manufactured in a Fair Wear audited facility when it comes from a factory proven to have had an on-site inspection / audit carried out within the past 3 years.\*



### **Lesser Impact**

In order for a product to carry our 'Lesser Impact', the product must be able to demonstrate that it has lowered its overall environmental impact by means other than those specifically listed above. For example, it may use a dyeing method that significantly reduces water and energy consumption. All such claims must be verifiable through supplier verification and material certification and traceability.

\* Please note that all suppliers must agree to the Fair Wear Code of Conduct and must agree to on-site inspections being carried out. More details on this and our status as a Leader Brand can be found on our website.

# Packs

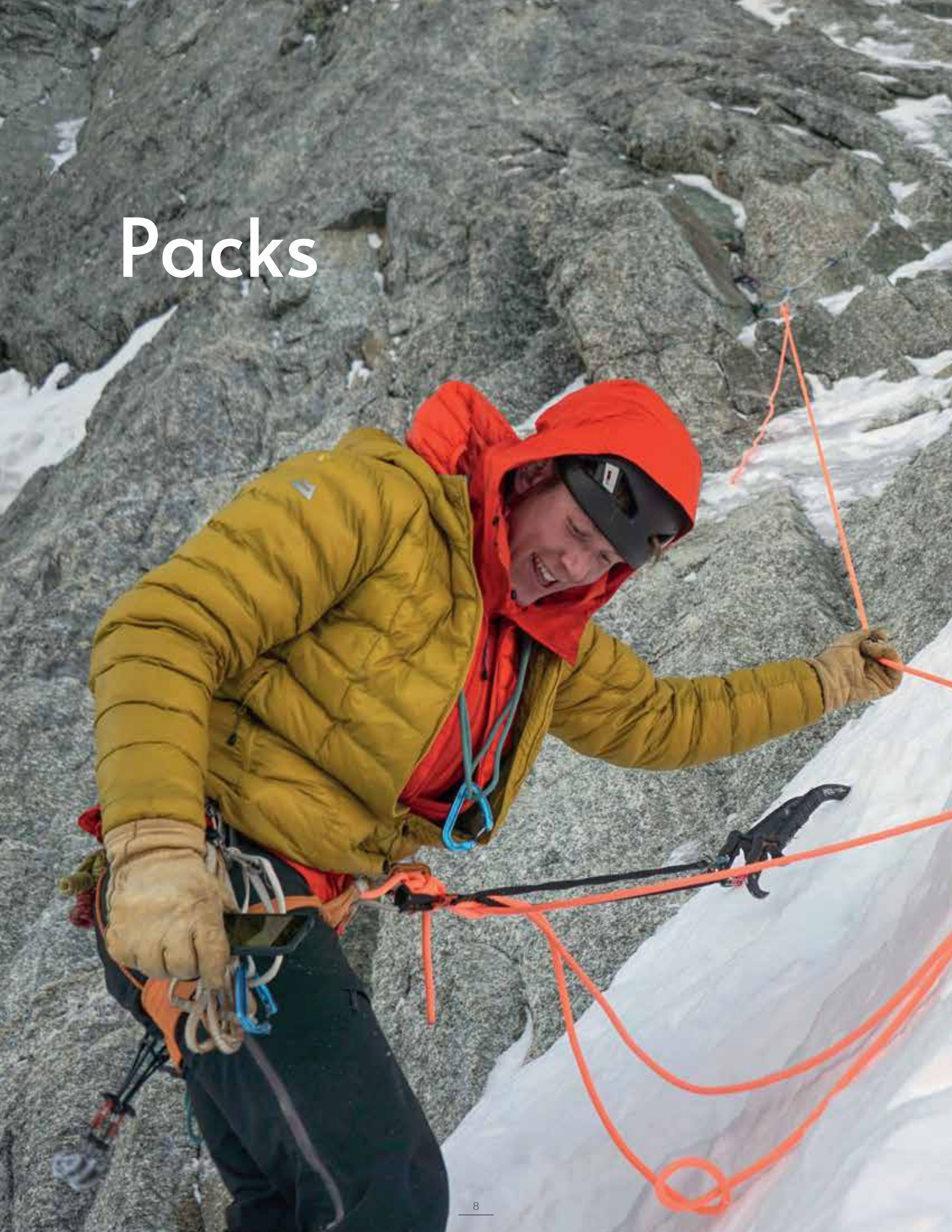





Matt Glenn  
Left: C  
Right: S  
Pellissier Glacier, Inverness  
Photography by Tom Livingstone



ME-004415

**TUPILEK 50-75**

This durable, highly weather resistant and lightweight expedition pack is the definitive choice for technical objectives on the highest peaks. Designed to comfortably carry big loads on long approaches it compresses to become a stripped back alpine pack on steeper ground.

- 50 litre optimum capacity extendable to 75 litres
- PACT™ 300 & 100 R2 fabrics; durable, lightweight and water resistant
- On Demand Minimalism; all components removable
- Drawcord closure for easy packing and rapid access
- Durable aluminium Grappler™ buckle\*
- Internal extension collar with drawcord closure for over-packing
- Side compression straps with aluminium Hammerhead™ toggles
- Removable thermoplastic composite frame panel
- High Density EVA shoulder straps and removable EVA back panel
- 40mm webbing hipbelt with removable High Density EVA moulded hip-fins
- Dual axe toggles with integrated pick pocket
- Daisy chain system, haul loops and internal hanging loops
- Supplied with Shockcord System

Min Weight: 650g / 1lb 7oz

Max Weight: 1040g / 2lb 5oz

Back Length: 47cm / 19in



ME-01415  
Magma

ME-006560

**TUPILEK 45+**

Ideal for multiday routes or the longest climbing days, this durable, highly weather-resistant yet lightweight climbing pack is optimised for alpine and winter climbing on the steepest lines and biggest faces.

- 45 litre optimum capacity
- PACT™ 300 & 100 R<sup>2</sup> fabrics; durable, lightweight and water resistant
- On Demand Minimalism; all components removable
- Integrated cowl-lid closure for easy packing and weather protection with durable aluminium Grappler™ buckle\*
- Internal 'floating' accessories pocket; accessible from inside or outside of pack
- Internal weather-proof cowl with roll-top closure
- Side compression straps with aluminium Hammerhead™ toggles
- High Density EVA back panel, shoulder straps and 38mm webbing hipbelt with removable hip-fins
- Dual axe toggles with integrated pick pocket
- Haul loops, Daisy Chain system and Shockcord system

Min Weight: 730g / 1lb 9.7oz

Max Weight: 1020g / 2lb 4oz

Back Length: 47cm / 19in



ME-01415  
Magma

ME-006025

**TUPILEK 37+**

Rewarding the minimalist and focussed alpinist with arguably our finest all-round pack. This durable, highly weather-resistant yet lightweight climbing and mountaineering pack is perfect for summer alpine and winter climbing on the steepest lines.

- 37 litre optimum capacity
- PACT™ 300 & 100 R<sup>2</sup> fabrics; durable, lightweight and water resistant
- On Demand Minimalism; all components removable
- Integrated cowl-lid closure for easy packing and weather protection with durable aluminium Grappler™ buckle\*
- Internal 'floating' accessories pocket; accessible from inside or outside of pack
- Internal weather-proof cowl with roll-top closure
- Side compression straps with aluminium Hammerhead™ toggles
- High Density EVA back panel, shoulder straps and 38mm webbing hipbelt with removable hip-fins
- Dual axe toggles with integrated pick pocket
- Haul loops, Daisy Chain system and Shockcord system

Min Weight: 680g / 1lb 8oz

Max Weight: 970g / 2lb 2.2oz

Back Length: 47cm / 19in



ME-01415  
Magma



ME-006559

**TUPILAK 30+**

The smallest of our durable, highly weather-resistant yet lightweight Tupilak series, this pack is ideal for minimalist alpinism and those climbing more accessible routes.

- 30 litre optimum capacity
- PACT™ 300 & 100 R<sup>2</sup> fabrics; durable, lightweight and water resistant
- On Demand Minimalism; all components removable
- Drawcord closure for easy access combined with roll top inner cowl for weather protection
- Internal 'floating' accessories pocket; accessible from inside or outside of pack
- Removable rope strap with durable aluminium Grappler™ buckle\*
- High Density EVA back panel, shoulder straps and 38mm webbing hipbelt with removable hip-fins
- Dual axe toggles and attachment points for side compression straps
- Haul loops, Daisy Chain system and Shockcord system

Min Weight: 580g / 1lb 4.5oz

Max Weight: 840g / 1lb 13.6oz

Back Length: 47cm / 19in



ME-01415  
Magma

ME-006168

**TUPILAK VEST 14**

A technical vest pack for fast moving mountain days in all weathers and across the seasons; as stable and light as a running pack and as rugged and functional as a climbing pack.

- 14 litre optimum capacity
- PACT™ 300 & 100 R<sup>2</sup> fabrics; durable, lightweight and water resistant
- Drawcord closure with integrated Cohesive cord lock and durable aluminium Grappler™ buckle\*
- Vest pack harness with large mesh pockets and zipped phone pocket
- Zipped internal pocket and large front stash pocket
- Side zip for rapid access into main pack body
- External sleeve pocket for pole stowage
- Recycled polyester air mesh harness and back panel
- Concealed dual axe retainers with integrated pick pocket
- Compression wing system to stabilise load

Min Weight: 420g / 14.8oz

Max Weight: 450g / 15.9oz

Sizes: S/M, L/XL



ME-01415  
Magma



NEW

FW

ME-006103

**FANG 42+**

A tough, versatile and strippable pack, the larger of our Fang series is ideally suited to year round mountaineering and more remote climbing and ski trips.

- 42 litre optimum capacity
- M420 ROBIC® N6,6 Carbonate fabrics throughout; abrasion resistant, tough and water resistant
- Fully removable floating lid with durable aluminium Grappler™ buckle closure\*
- Dual-stage drawcord closure for weather protection and overstuffing
- Spacious zipped lid pocket and inner security pocket
- Side zip for rapid access into main pack body
- Side compression straps with thermoplastic buckles
- EVA composite shoulder straps and thermoformed back panel
- Custom moulded HDPE framesheet offers superb load transfer for comfortable carry
- 38mm webbing hipbelt with removable High Density EVA hip-fins

\* Community Design Number:  
0041002614-0001-0002

*Min Weight:* 880g / 1lb 15oz

*Max Weight:* 1270g / 2lb 12.8oz

*Back Length:* 47cm / 19in



ME-01505  
Alaskan Blue



ME-01527  
Sulphur

NEW

FW

ME-006104

**FANG 35+**

A versatile all-round mountaineering pack, as at home while cragging as it is on big alpine faces. Tough and strippable, it can be used with or without its lid.

- 35 litre optimum capacity
- M420 ROBIC® N6,6 Carbonate fabrics throughout; abrasion resistant, tough and water resistant
- Fully removable floating lid with durable aluminium Grappler™ buckle closure\*
- Dual-stage drawcord closure for weather protection and overstuffing
- Spacious zipped lid pocket and inner security pocket
- Side zip for rapid access into main pack body
- Side compression straps with thermoplastic buckles
- EVA composite shoulder straps and thermoformed back panel
- Custom moulded HDPE framesheet offers superb load transfer for comfortable carry
- 38mm webbing hipbelt with removable High Density EVA hip-fins

\* Community Design Number:  
0041002614-0001-0002

*Min Weight:* 860g / 1lb 14.3oz

*Max Weight:* 1250g / 2lb 12.1oz

*Back Length:* 47cm / 19in



ME-01527  
Sulphur



ME-01505  
Alaskan Blue

ME-005404

**ORCUS 28+**

Light enough to be carried on multi-pitch rock routes, the Orcus 28+ also has sufficient volume for approaching big faces and lightning raids on Alpine classics.

- 28 litre optimum capacity
- M210 ROBIC® N6,6 fabrics throughout; abrasion resistant and lightweight
- Rolltop closure for weather resistance
- Zipped pocket
- Removable ropestrap with aluminium Grappler™ buckle\*
- Removable EVA back panel
- EVA composite shoulder straps
- Removable 38mm webbing hipbelt
- Dual webbing axe retainers
- Daisy Chain and compression cord system and haul loops
- Hydration system compatible

\* Community Design Number:  
0041002614-0001-0002

*Min Weight:* 420g / 14.8oz

*Max Weight:* 520g / 1 lb 2.3oz

*Back Length:* 47cm / 19in



ME-01437  
Alto Blue



ME-01560  
Anvil Grey

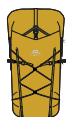

ME-01527  
Sulphur

ME-005327

**ORCUS 22+**

A dedicated lightweight climbing pack that excels on the fastest moving Alpine days as well as being an ideal choice for carrying essentials on the steepest lines.

- 22 litre optimum capacity
- M210 ROBIC® N6,6 Carbonate fabrics throughout; abrasion resistant, lightweight and water resistant
- Rolltop closure for weather resistance
- Zipped pocket
- Removable ropestrap with aluminium Grappler™ buckle\*
- Removable EVA back panel
- EVA composite shoulder straps
- Removable 20mm webbing hipbelt
- Dual webbing axe retainers
- Daisy Chain and compression cord system and haul loops
- Hydration system compatible

\* Community Design Number:  
0041002614-0001-0002

*Min Weight:* 400g / 14.1oz

*Max Weight:* 500g / 1 lb 1.6oz

*Back Length:* 47cm / 19in



ME-01560  
Anvil Grey



ME-01437  
Alto Blue

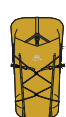

ME-01527  
Sulphur



ME-005403

**WALLPACK 20**

Large enough for full days on the wall this robust climbing pack fits all the essentials for the biggest, steepest lines whilst easily handling daily life when you find yourself back in the horizontal.

- 20 litre optimum capacity
- M210 fabrics; lightweight and durable
- Zip-top closure for fast access and weather resistance
- Large accessories pocket in lid with zip closure
- Zipped valuables pocket inside lid
- EVA back panel with internal padded sleeve
- Comfortable EVA mono-foam shoulder harness
- Removable 20mm webbing hipbelt
- Haul loops
- Hydration system compatible

*Min Weight:* 550g / 1 lb 3.4oz

*Max Weight:* 590g / 1 lb 4.8oz

*Back Length:* 47cm / 19in



ME-01437  
Alto Blue



ME-01629  
Anvil Grey/  
Cardinal Orange



ME-01560  
Anvil Grey

ME-005310

**WALLPACK 16**

Designed to thrive in the vertical world this is a robust climbing pack for the rough and the smooth of life on multi-pitch routes. Stuffed with team essentials it still sits clear of a chalk bag and can easily be hauled at the crux if required.

- 16 litre optimum capacity
- M210 fabrics; lightweight and durable
- Zip-top closure for fast access and weather resistance
- Large accessories pocket in lid with zip closure
- Zipped valuables pocket inside lid
- EVA back panel with internal padded sleeve
- Comfortable EVA mono-foam shoulder harness
- Removable 20mm webbing hipbelt
- Haul loops
- Hydration system compatible

*Min Weight:* 510g / 1 lb 2oz

*Max Weight:* 550g / 1 lb 3.4oz

*Back Length:* 44cm / 19in



ME-01629  
Anvil Grey/  
Cardinal Orange



ME-01437  
Alto Blue



ME-01560  
Anvil Grey





# Sleeping Mats







Richard Bailey & Kerry Mellor,  
Leck, Airedale, Calderdale  
Photography by Hamish Frost





## SLEEPING MATS

---

An essential part of any sleeping system, a mat is every bit as important as a good sleeping bag. Our range of sleeping mats includes self-inflating foam mats and our innovative Aerostat series of insulated pressurised air mats.

---



## AEROSTAT DOWN

A down filled sleeping mat that gives exceptional insulation and comfort with a small pack size.

- 180g of 90-10 Pure Duck Down with a minimum fill power of 700
- Vertically aligned baffles with Helix technology to reduce down migration
- ↳ Recycled 30D ripstop polyester with TPU lamination
- 2-way self-sealing Gas Mask valve for inflation and deflation
- Supplied Windsock™ inflates mat easily and doubles as lightweight stuff sack
- Supplied with repair patches
- R Value: 5.0, tested to ASTM F3340\*

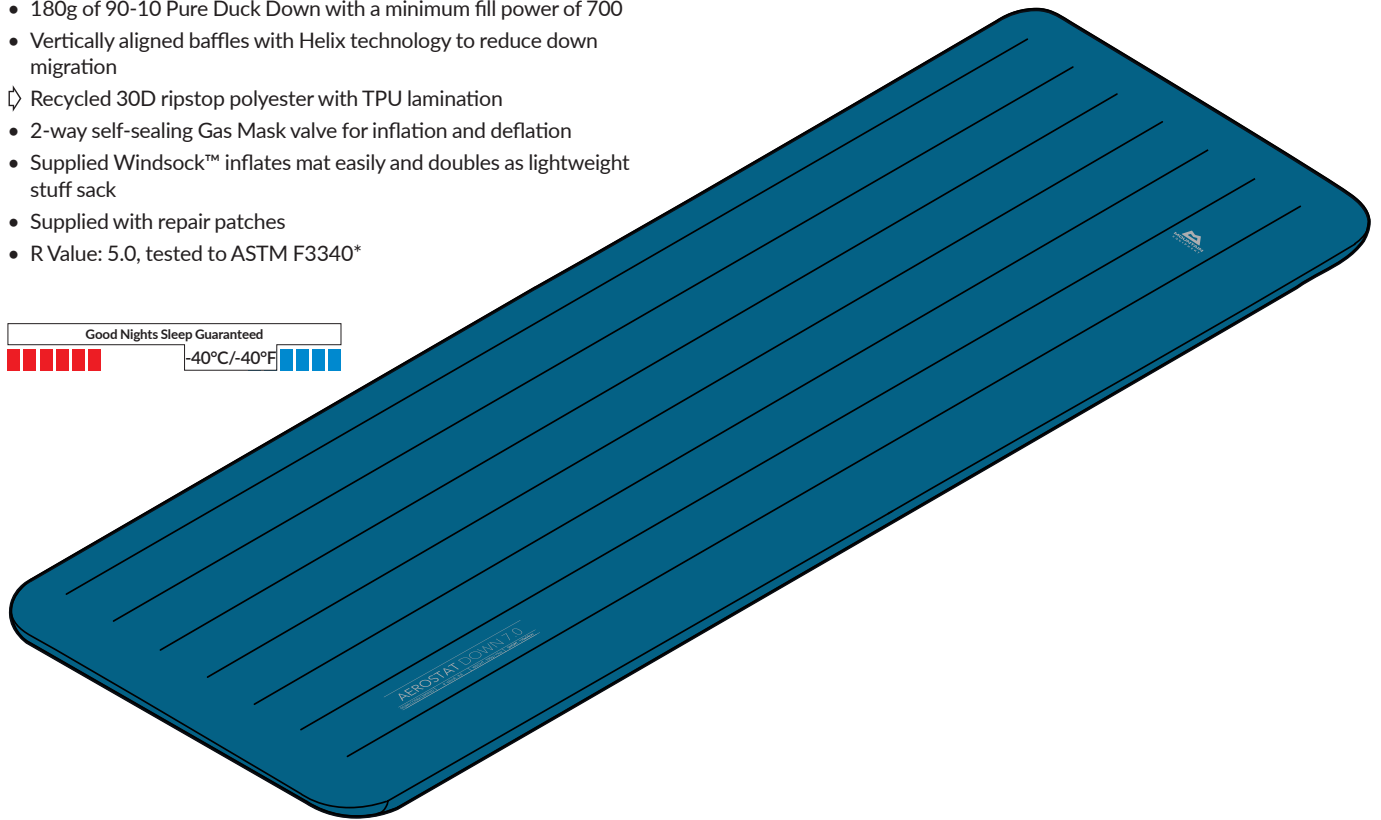
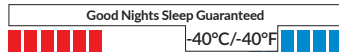

### 7.0

<b>REGULAR</b>	ME-006093
Weight:	735g / 1lb 10oz
Length:	185cm
Width:	54cm
Thickness:	7cm / 2.8in
Colour:	ME-01678 Mykonos Blue

### 7.0

<b>LONG</b>	ME-006094
Weight:	855g / 1lb 14oz
Length:	200cm
Width:	60cm
Thickness:	7cm / 2.8in
Colour:	ME-01678 Mykonos Blue

\*ASTM F3340 is the outdoor industry's first Standard method for testing the thermal performance of sleeping mats. It is designed to make comparisons between different brands' mats easier, and to ensure consistency of testing in the marketplace. Mountain Equipment were involved in the development and writing of ASTM F3340, and as of Spring Summer 2020 onwards all our mats have been tested using this new method.



## AEROSTAT DOWN ULTRA

A down filled sleeping mat with harder wearing outer fabric that is durably warm for long-lasting comfort.

- 180g of 90-10 Pure Duck Down with a minimum fill power of 700
- Vertically aligned baffles with Helix technology to reduce down migration
- 150D polyester with TPU lamination
- 2-way self-sealing Gas Mask valve for inflation and deflation
- Supplied Windsock™ inflates mat easily and doubles as lightweight stuff sack
- Supplied with repair patches
- R Value: 5.0, tested to ASTM F3340\*

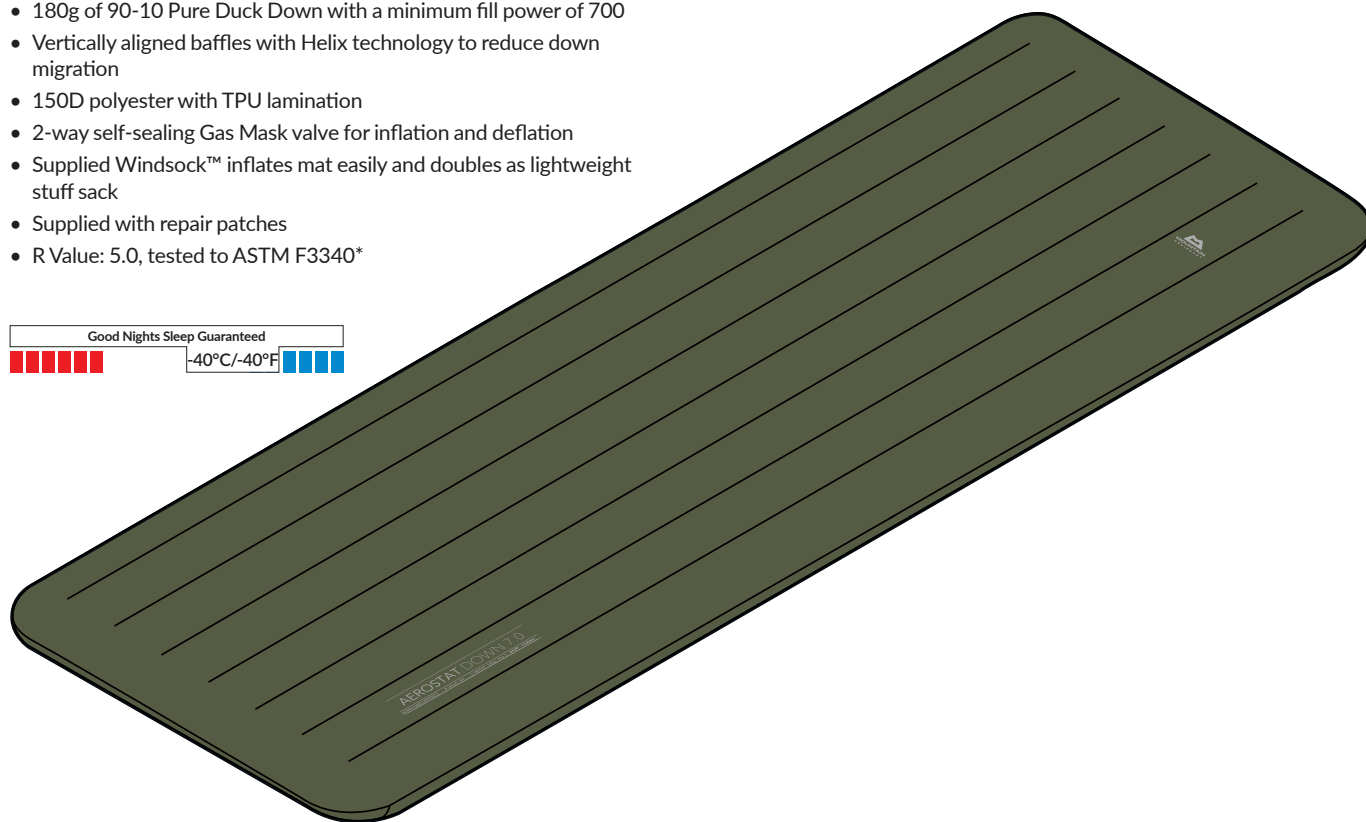

### 7.0 WIDE

<b>REGULAR</b>	ME-006234
<i>Weight:</i>	1035g / 2lb 4oz
<i>Length:</i>	185cm
<i>Width:</i>	63cm
<i>Thickness:</i>	7cm / 2.8in
<i>Colour:</i>	ME-01556 Hunt Green

### 7.0

<b>LONG</b>	ME-006235
<i>Weight:</i>	1055g / 2lb 5oz
<i>Length:</i>	200cm
<i>Width:</i>	60cm
<i>Thickness:</i>	7cm / 2.8in
<i>Colour:</i>	ME-01556 Hunt Green

\*ASTM F3340 is the outdoor industry's first Standard method for testing the thermal performance of sleeping mats. It is designed to make comparisons between different brands' mats easier, and to ensure consistency of testing in the marketplace. Mountain Equipment were involved in the development and writing of ASTM F3340, and as of Spring Summer 2020 onwards all our mats have been tested using this new method.

## AEROSTAT SYNTHETIC

A synthetically insulated sleeping mat that gives high levels of warmth, exceptional comfort and small pack size.

- Welded 160g m<sup>2</sup> Polarloft® for maximum insulation
- Vertically aligned baffles
- ↳ Recycled 30D ripstop polyester with TPU lamination
- 2-way self-sealing Gas Mask valve for inflation and deflation
- Supplied Windsock™ inflates mat easily and doubles as lightweight stuff sack
- Supplied with repair patches
- R Value: 4.0, tested to ASTM F3340\*

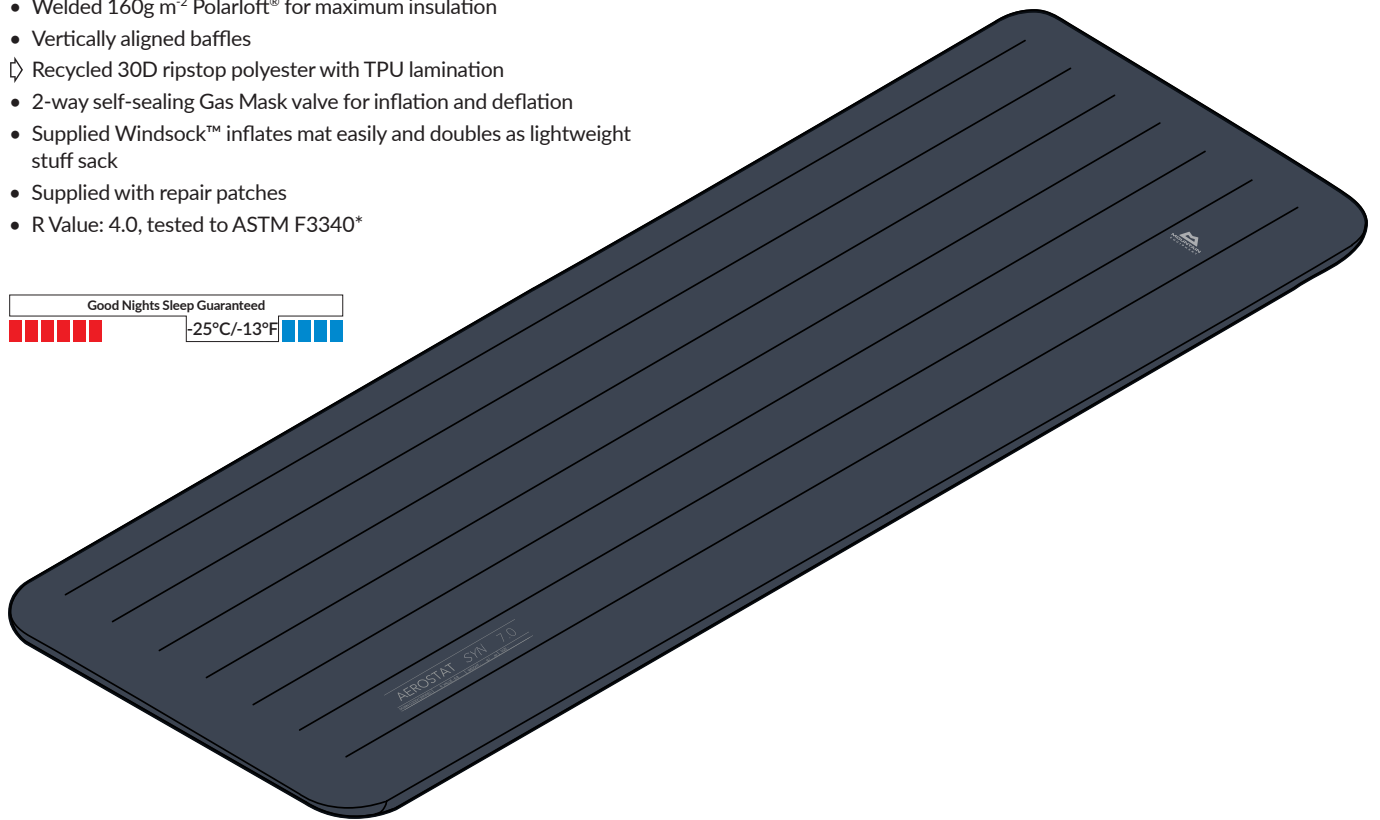
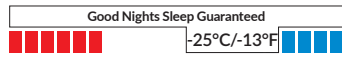

7.0	<b>REGULAR</b>	ME-006098
<i>Weight:</i>	665g / 1lb 7oz	
<i>Length:</i>	185cm	
<i>Width:</i>	54cm	
<i>Thickness:</i>	7cm / 2.3in	
<i>Colour:</i>	ME-01318 - Ombre Blue	

7.0	<b>LONG</b>	ME-006099
<i>Weight:</i>	765g / 1lb 14oz	
<i>Length:</i>	200cm	
<i>Width:</i>	60cm	
<i>Thickness:</i>	7cm / 2.3in	
<i>Colour:</i>	ME-01318 - Ombre Blue	



## AEROSTAT SYNTHETIC ULTRA

A synthetically insulated sleeping mat with harder wearing outer fabric that is durably warm for long-lasting comfort.

- Welded 160g m<sup>2</sup> Polarloft® for maximum insulation
- Vertically aligned baffles
- 150D polyester with TPU lamination
- 2-way self-sealing Gas Mask valve for inflation and deflation
- Supplied Windsock™ inflates mat easily and doubles as lightweight stuff sack
- Supplied with repair patches
- R Value: 4.0, tested to ASTM F3340\*

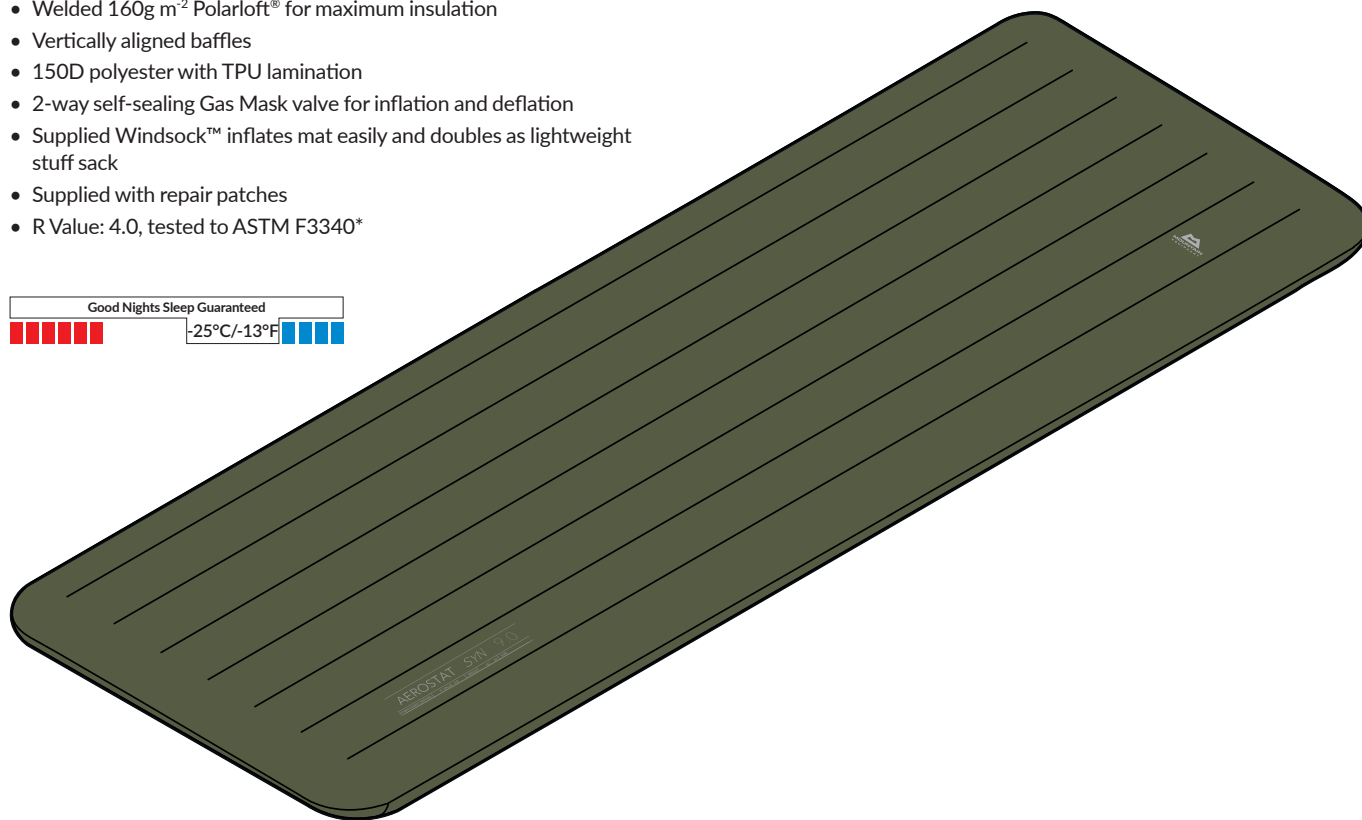
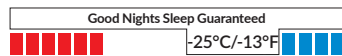

### 9.0 WIDE

<b>LONG</b>	ME-006236
<b>Weight:</b>	1065g / 2lb 6oz
<b>Length:</b>	200cm
<b>Width:</b>	65cm
<b>Thickness:</b>	9.0cm
<b>Colour:</b>	ME-01556 - Hunt Green

ME-006096

## AEROSTAT WINDSOCK™

The fastest way to inflate your insulated sleeping mat.

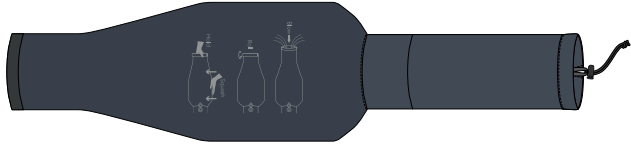

- Rolltop polyester Windssock™ inflates mats quickly
- Shape optimised for ease of use and air expulsion
- Rolls into itself to form stuffsack with drawstring closure
- Internal pouch for storage of repair kit (not included)
- Compatible with Mountain Equipment Aerostat sleeping mats

Weight: 65g / 2.3oz  
 Colour: ME-01318 Ombre Blue

\* Note: A Windssock™ is included with all Aerostat sleeping mats

ME-006164

## SLEEPING MAT SERVICE KIT

Everything you need to make running repairs to your mat if damage occurs whilst out on expedition.



- Compatible with any Mountain Equipment Aerostat, Hoverstat or self-inflating mat
- Contains glue, fabric patches, rubber O rings, spare valve for self-inflating mats, TPU patches and instructions

Weight: 30g / 1oz  
 Colour: ME-01456 - Mixed Colour

ME-003231

## AEROSTAT REPAIR KIT

Should the worst happen, our repair kit will fix your mat right up.

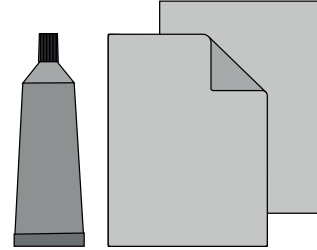

- Compatible with Mountain Equipment air mats
- Contains x2 fabric patches, x2 TPU patches, x2 O rings, x1 glue tube

\* Note: A Repair Kit is included with all Aerostat sleeping mats

## HOVERSTAT SYNTHETIC

A lightweight mat with synthetic insulation that gives great comfort and low pack size.

- Vertically aligned chambers
- 160g m<sup>-2</sup> 85% recycled POLARLOFT® insulation
- 75D fabric with TPU lamination and 100% recycled polyester face
- 2-way self-sealing Gas Mask valve for inflation and deflation
- Supplied Windsock™ made from recycled polyester inflates mat easily and doubles as lightweight stuff sack
- R Value: 3.5, tested to ASTM F3340\*

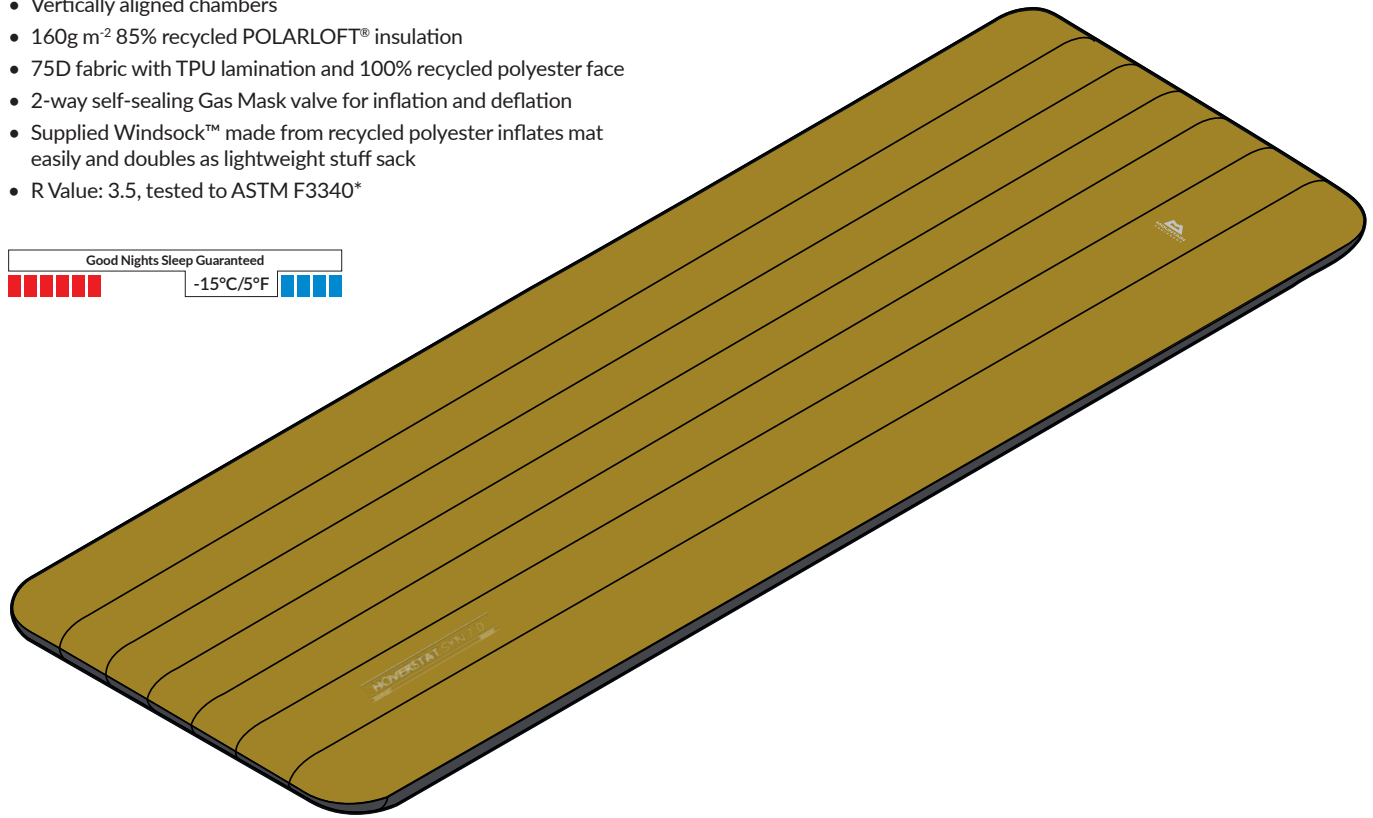

**7.0**  
**REGULAR** ME-006803

Weight:	_____g / _____oz
Length:	183cm
Width:	50cm
Thickness:	6.5cm / 2.6in
Colour:	ME-01639 - Acid/Anvil Grey

**7.0**  
**LONG** ME-006804

Weight:	_____g / _____oz
Length:	198cm
Width:	50cm
Thickness:	6.5cm / 2.6in
Colour:	ME-01639 - Acid/Anvil Grey



## HOVERSTAT

A lightweight and comfortable mat with a small packsize for less severe conditions and minimalist trips.

- Vertically aligned chambers
- 75D fabric with TPU lamination and 100% recycled polyester face
- 2-way self-sealing Gas Mask valve for inflation and deflation
- Supplied Windsock™ made from recycled polyester inflates mat easily and doubles as lightweight stuff sack
- R Value: 2.0, tested to ASTM F3340\*

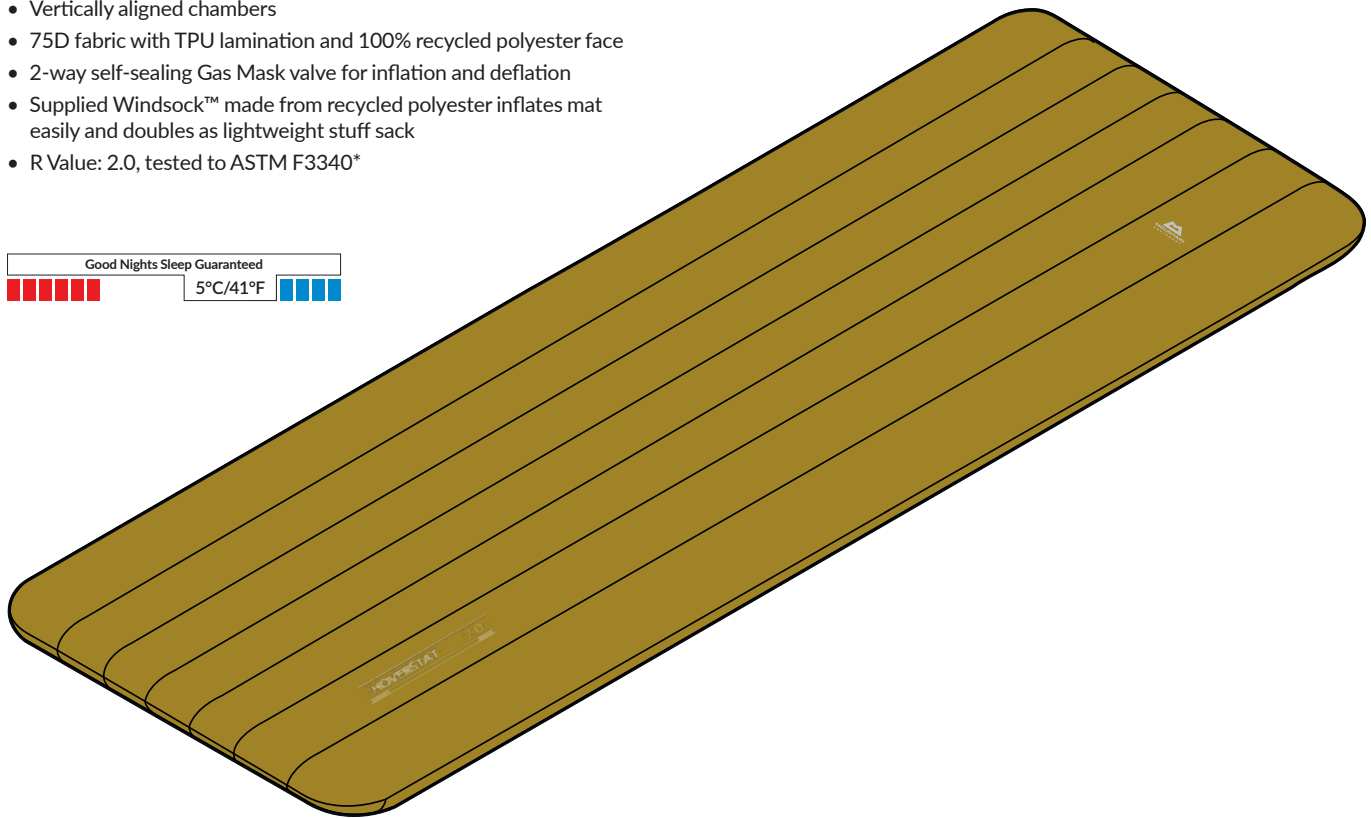

<b>7.0</b>	
<b>REGULAR</b>	ME-006807
Weight:	_____ g / _____ oz
Length:	183cm
Width:	50cm
Thickness:	6.5cm / 2.6in
Colour:	ME-01514 Acid

<b>7.0</b>	
<b>LONG</b>	ME-006808
Weight:	_____ g / _____ oz
Length:	198cm
Width:	50cm
Thickness:	6.5cm / 2.6in
Colour:	ME-01514 Acid

\*ASTM F3340 is the outdoor industry's first Standard method for testing the thermal performance of sleeping mats. It is designed to make comparisons between different brands' mats easier, and to ensure consistency of testing in the marketplace. Mountain Equipment were involved in the development and writing of ASTM F3340, and as of Spring Summer 2020 onwards all our mats have been tested using this new method.

# Down Sleeping Bags







Martin Feistl & Amélie Kühne,  
Aiguille Noire de Peuterey,  
Photography by Silvan Weitz



# EXTREME EXPEDITION

---

Engineered to withstand extreme cold in the most hostile environments on earth. With durably rain-resistant fabrics and construction optimised to maximise and maintain warmth for extended periods these bags are built specifically for the needs of explorers and mountaineers undertaking the most committing journeys in the highest, coldest and most remote locations.

---



## REDLINE

Our warmest sleeping bag. Suitable for the very coldest conditions encountered during Polar expeditions.

- GORE-TEX INFINIUM™ 10D outer shell is durably light, highly breathable and rain-resistant
- 1282g of 90-10 European Goose Down with a minimum fill power of 800
- Expedition fit with EXL system is both roomier and has improved loft and thermal efficiency
- V chest and foot baffles & Trapezoid main body baffles
- Optimised down distribution and fill weights using a baffle-by-baffle approach
- Ground level side seams with V-side baffle
- 7 baffle low volume anatomically shaped hood
- 6 baffle anatomically shaped offset foot-box
- Full length Gemini zip baffle with 140cm zip and integrated neck collar with Lode Lock closure
- GORE-TEX INFINIUM™ 10D inner foot-box and hood lining
- Inner pocket for keeping essentials warm and dry
- Supplied with waterproof roll-top stuff-sack and storage cube

Fill Weight: 1282g / 2lb 13oz

Total Weight: 1980g / 4lb 6oz

Std Pack Size: 30cm x 29cm x 26cm

Bag Fit: Regular & Long

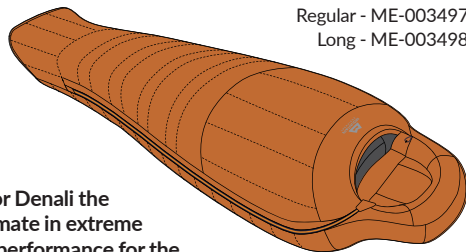
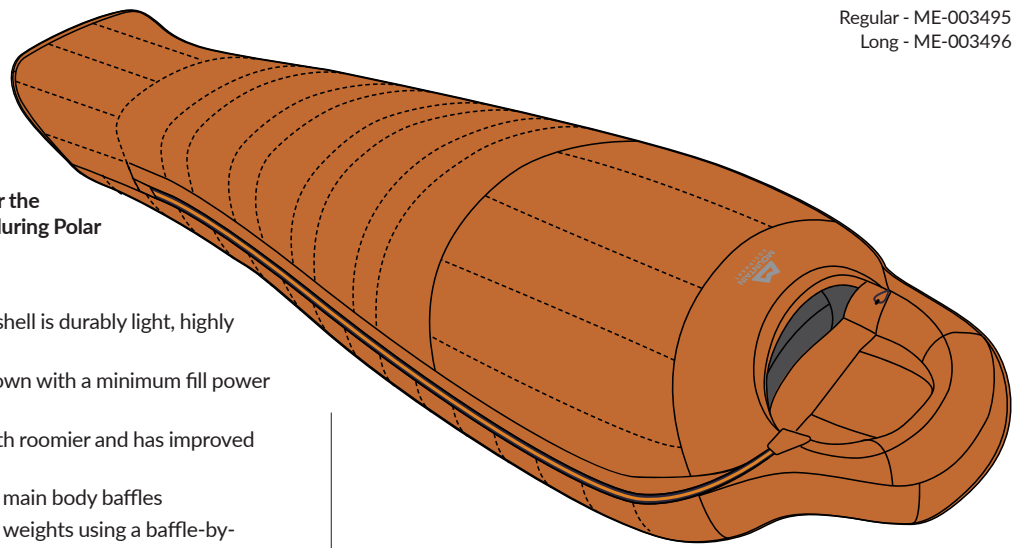
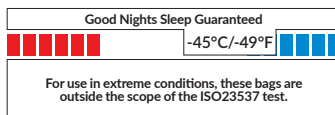

Regular - ME-003497  
Long - ME-003498

## ICELINE

Whether on K2 or Denali the Iceline is the ultimate in extreme mountaineering performance for the coldest of conditions.

- GORE-TEX INFINIUM™ 10D outer shell is durably light, highly breathable and rain-resistant
- 994g of 90-10 European Goose Down with a minimum fill power of 800
- Expedition fit with EXL system is both roomier and has improved loft and thermal efficiency
- V chest and foot baffles & Trapezoid main body baffles
- Optimised down distribution and fill weights using a baffle-by-baffle approach
- Ground level side seams with V-side baffle
- 7 baffle low volume anatomically shaped hood
- 6 baffle anatomically shaped offset foot-box
- Full length Gemini zip baffle with 140cm zip and integrated neck collar with Lode Lock closure
- GORE-TEX INFINIUM™ 10D inner foot-box and hood lining
- Inner pocket for keeping essentials warm and dry
- Supplied with waterproof roll-top stuff-sack and storage cube

Fill Weight: 994g / 2lb 3oz

Total Weight: 1650g / 3lb 10oz

Std Pack Size: 31cm x 27cm x 24cm

Bag Fit: Regular & Long

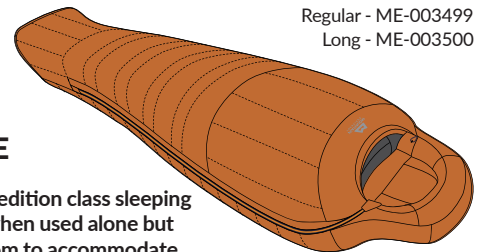
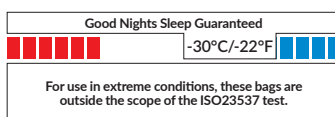

Regular - ME-003499  
Long - ME-003500

## SNOWLINE

Our lightest expedition class sleeping bag. Ultralight when used alone but with enough room to accommodate clothing when pushed to its absolute limit.

- GORE-TEX INFINIUM™ 10D outer shell is durably light, highly breathable and rain-resistant
- 831g of 90-10 European Goose Down with a minimum fill power of 800
- Expedition fit with EXL system is both roomier and has improved loft and thermal efficiency
- V chest and foot baffles & Trapezoid main body baffles
- Optimised down distribution and fill weights using a baffle-by-baffle approach
- Ground level side seams with V-side baffle
- 7 baffle low volume anatomically shaped hood
- 6 baffle anatomically shaped offset foot-box
- Full length Gemini zip baffle with 140cm zip and integrated neck collar with Lode Lock closure
- GORE-TEX INFINIUM™ 10D inner foot-box and hood lining
- Inner pocket for keeping essentials warm and dry
- Supplied with waterproof roll-top stuff-sack and storage cube

Fill Weight: 831g / 1lb 13oz

Total Weight: 1490g / 3lb 5oz

Std Pack Size: 30cm x 24cm x 21cm

Bag Fit: Regular & Long

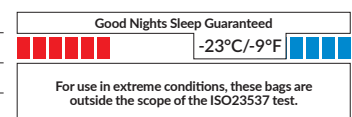





# EXTREME ALPINE

---

Built for Alpinism at higher elevations, our Extreme Alpine series are expedition bags in all but weight. Now with a more adaptable yet technical Alpine 2.0 fit and revised EXL® system they are lighter and more protective than before. These bags have been re-developed with marginal gains in mind, specifically for climbers and mountaineers faced with the prospect of climbing over thousands of metres of technical terrain. Highly efficient, exceptionally warm and protective, these are bags designed for Alpinism's leading edge.

---



## KRYOS

Designed for alpine winter mountaineering and remote backcountry ski expeditions, this is one of the most reliably warm yet light and packable bags available.

- DRILITE® LOFT 10D outer shell is ultra-light, highly breathable and water-resistant
- 743g of 90-10 European Goose Down with a minimum fill power of 800
- Alpine Fit with revised EXL system improves comfort and loft whilst maximising thermal efficiency
- Trapezoid baffles throughout
- Ground level side seams
- 7 baffle low volume anatomically shaped hood
- 6 baffle anatomically shaped and offset foot-box
- Full length Gemini zip baffle with 140cm zip and integrated neck collar with Lode Lock closure
- DRILITE® LOFT 10D inner foot-box, collar and hood lining, and Ultrasoft™ 10D lining
- Supplied with waterproof roll-top stuff-sack and storage cube

Fill Weight: 743g / 1lb 10oz	Good Nights Sleep Guaranteed		
Total Weight: 1150g / 2lb 8.6oz	-20°C/-4°F		
Std Pack Size: 34cm x 25cm x 24cm	Comfort	Comfort Limit	Extreme
Bag Fit: Regular & Long	-9°C/16°F	-16°C/3°F	-37°C/-35°F

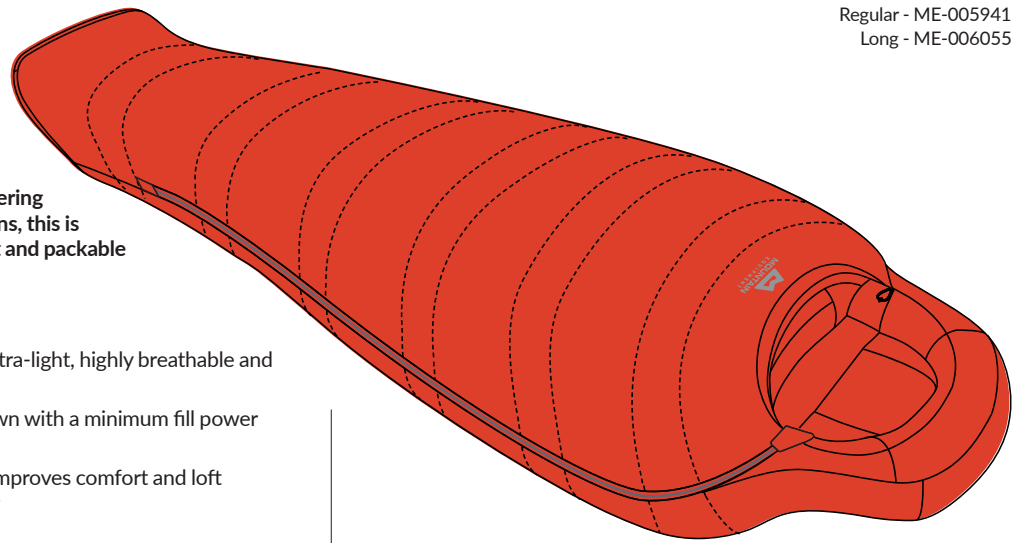

## XEROS

An ultra-light winter bag with a water resistant shell that's purpose built for those pushing the envelope of super-alpine climbing on hard, multi-day routes.

- DRILITE® LOFT™ 10D outer shell is ultra-light, highly breathable and water-resistant
- 605g of 90-10 European Goose Down with a minimum fill power of 800
- Alpine Fit with revised EXL system improves comfort and loft whilst maximising thermal efficiency
- Trapezoid baffles throughout
- Ground level side seams
- 7 baffle low volume anatomically shaped hood
- 6 baffle anatomically shaped and offset foot-box
- Full length Gemini zip baffle with 140cm zip and integrated neck collar with Lode Lock closure
- DRILITE® LOFT 10D inner foot-box, collar and hood lining, and Ultrasoft™ 10D lining
- Supplied with waterproof roll-top stuff-sack and storage cube

Fill Weight: 605g / 1lb 5oz	Good Nights Sleep Guaranteed		
Total Weight: 1010g / 2lb 3.6oz	-14°C/7°F		
Std Pack Size: 27cm x 24cm x 24cm	Comfort	Comfort Limit	Extreme
Bag Fit: Regular & Long	-5°C/23°F	-12°C/10°F	-32°C/-26°F

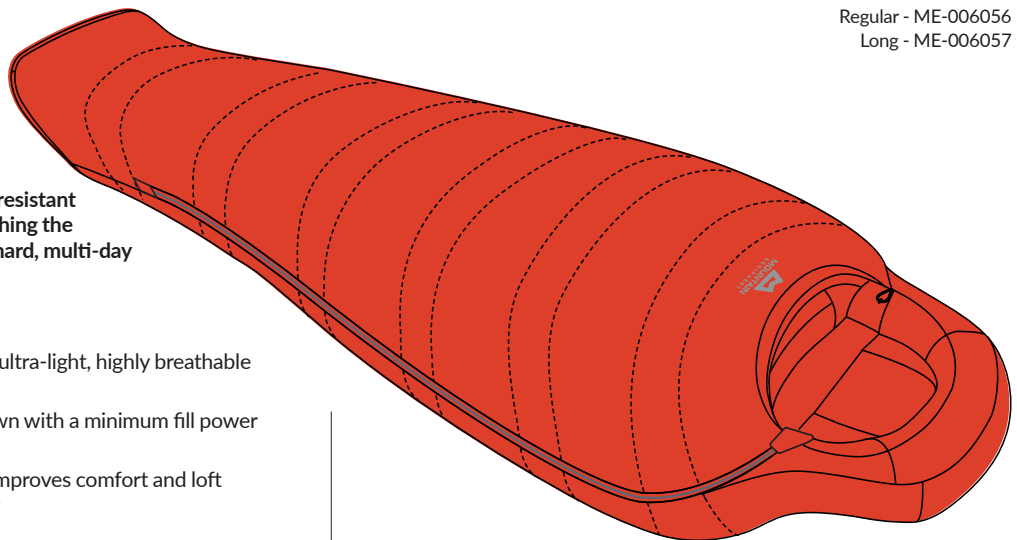



# EXTREME LIGHT

---

Our Extreme Light series of sleeping bags have become the bags of choice for those looking for an exceptionally light bag with a reputation for outstanding performance and reliable warmth. Now boasting unparalleled loft thanks to the use of 900 fill-power Goose Down and constructed using an entirely new Alpine 2.0 Fit block, each of the 'Fire' bags have an ultra-premium feel that can excel in almost any environment and for almost any user.

---

plasma™



DOWN  
900





## FIREFLASH

The warmest of our lightest bags. With exceptionally high quality 900 fill power down and optimised fit this is the perfect choice for going fast and light in the mountains.

- PLASMA 10D fabrics throughout are incredibly light and breathable with PFC free DWR
- 610g of 90-10 European Goose Down with a minimum fill power of 900
- Alpine Fit with revised EXL system improves comfort and loft whilst maximising thermal efficiency
- Slanted box-wall baffles throughout
- Ground level side seams
- 7 baffle low volume anatomically shaped hood
- 4 baffle anatomically shaped and offset foot-box
- Full length Gemini zip baffle with 140cm zip and integrated neck collar
- Plasma™ 10D inner throughout with PFC free DWR
- Supplied with waterproof roll-top stuff-sack and storage cube

Fill Weight: 610g / 1lb 6oz	Good Nights Sleep Guaranteed		
Total Weight: 950g / 2lb 1.5oz	-16°C/3°F		
Std Pack Size: 28cm x 23cm x 22cm	Comfort	Comfort Limit	Extreme
Bag Fit: Regular & Long	-7°C/19°F	-14°C/7°F	-34°C/-29°F

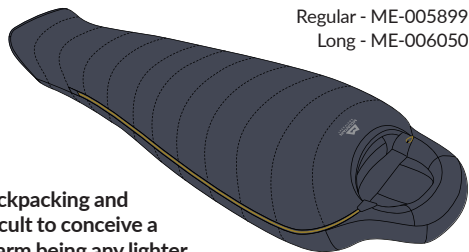
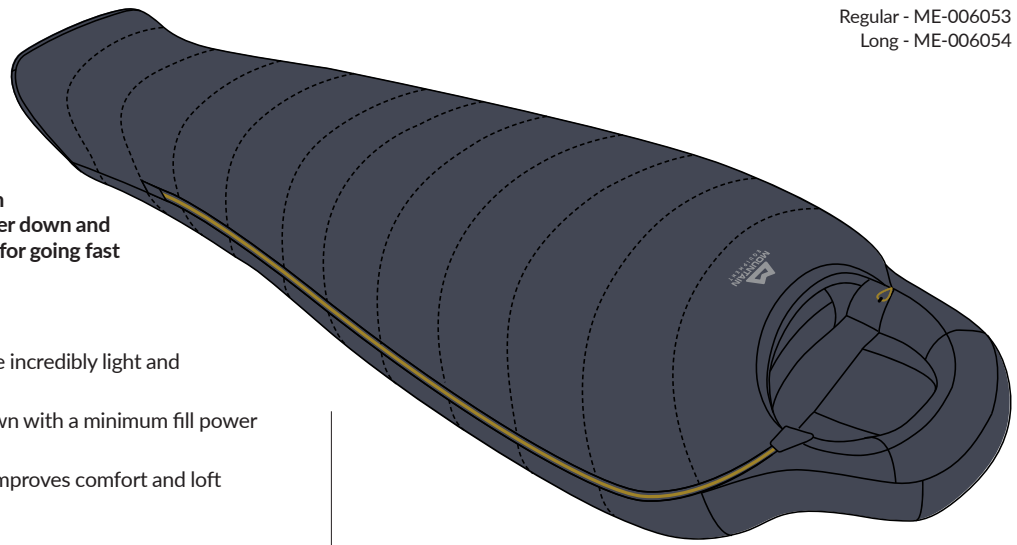

Regular - ME-005899  
Long - ME-006050

## FIRELITE

For ultra-light backpacking and alpinism it is difficult to conceive a bag so reliably warm being any lighter. Perfect for high mountain use during the summer and at lower altitudes in Spring and Autumn.

- PLASMA 10D fabrics throughout are incredibly light and breathable with PFC free DWR
- 436g of 90-10 European Goose Down with a minimum fill power of 900
- Alpine Fit with revised EXL system improves comfort and loft whilst maximising thermal efficiency
- Slanted box-wall baffles throughout
- Ground level side seams
- 7 baffle low volume anatomically shaped hood
- 4 baffle anatomically shaped and offset foot-box
- Full length Gemini zip baffle with 140cm zip and integrated neck collar
- Plasma™ 10D inner throughout with PFC free DWR
- Supplied with waterproof roll-top stuff-sack and storage cube

Fill Weight: 436g / 15oz	Good Nights Sleep Guaranteed		
Total Weight: 770g / 1lb 11.2oz	-9°C/16°F		
Std Pack Size: 25cm x 21cm x 20cm	Comfort	Comfort Limit	Extreme
Bag Fit: Regular & Long	-2°C/28°F	-8°C/18°F	-26°C/-15°F

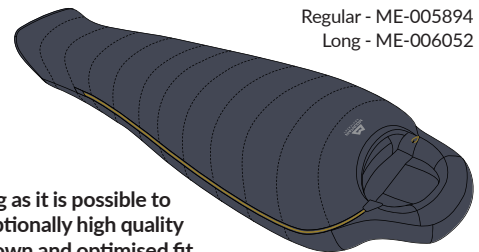

Regular - ME-005894  
Long - ME-006052

## FIREFLY

As efficient a bag as it is possible to make with exceptionally high quality 900 fill power down and optimised fit, this ultralight bag will pack a punch in any high mountain environment during the late spring and summer.

- PLASMA 10D fabrics throughout are incredibly light and breathable with PFC free DWR
- 252g of 90-10 European Goose Down with a minimum fill power of 900
- Alpine Fit with revised EXL system improves comfort and loft whilst maximising thermal efficiency
- Slanted box-wall baffles throughout
- Ground level side seams
- 7 baffle low volume anatomically shaped hood
- 4 baffle anatomically shaped and offset foot-box
- Full length Gemini zip baffle with 140cm zip and grown-on front collar
- Plasma™ 10D inner throughout with PFC free DWR
- Supplied with waterproof roll-top stuff-sack and storage cube

Fill Weight: 252g / 9oz	Good Nights Sleep Guaranteed		
Total Weight: 550g / 1lb 3.4oz	-3°C/27°F		
Std Pack Size: 21cm x 18cm x 16cm	Comfort	Comfort Limit	Extreme
Bag Fit: Regular & Long	4°C/39°F	-2°C/28°F	-18°C/0°F



# GLACIER

---

In a world of challengers, each of the Glacier models sits first among equals. Developed specifically to be best in class they offer true all-round performance and protection for unreliable conditions. Whether you are on a 3-week tent-based trek in the Himalaya, hauling a pulk across the Greenland icecap or mountaineering in the Cascades there is a Glacier bag for almost every mountain and cold weather adventure.

---



NEW

Regular - ME-006542  
Long - ME-006746

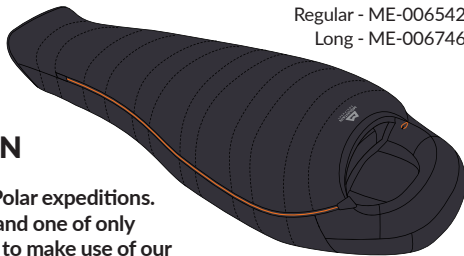

## GLACIER EXPEDITION

An ideal bag for Polar expeditions. Incredibly warm and one of only a handful of bags to make use of our roomier Expedition fit, it is well suited to nights on ice.

- DRILITE® LOFT outer shell is lightweight, breathable and water resistant
- 1326g of 90-10 Pure Duck Down with a minimum fill power of 700
- Expedition fit is roomier for additional clothing
- Trapezoid baffles and slanted box-wall baffles
- Mid-level side seams
- 5 baffle anatomically shaped hood
- 6 baffle anatomically shaped and offset foot-box
- Full length Gemini zip baffle with 140cm zip and integrated collar with Lode Lock closure
- DRILITE® LOFT hood lining
- Supplied with waterproof roll-top stuff-sack and storage cube

Fill Weight: 1326g / 2lb 15oz

Total Weight: 1920g / 4lb 3.7oz

Std Pack Size: 34cm x 29cm x 25cm

Bag Fit: Regular & Long

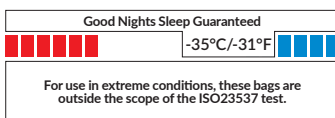

NEW

Regular - ME-006745  
Long - ME-006747

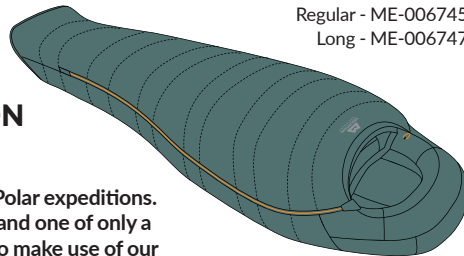

## GLACIER EXPEDITION WOMEN'S

An ideal bag for Polar expeditions. Incredibly warm and one of only a handful of bags to make use of our roomier Expedition fit, it is well suited to nights on ice.

- DRILITE® LOFT outer shell is lightweight, breathable and water resistant
- 1478g of 90-10 Pure Duck Down with a minimum fill power of 700
- Women's Expedition fit with zoned EXL system is roomier for additional clothing
- Trapezoid baffles and slanted box-wall baffles
- Mid-level side seams
- 5 baffle anatomically shaped hood
- 6 baffle anatomically shaped and offset foot-box
- Full length Gemini zip baffle with 140cm zip and integrated collar with Lode Lock closure
- DRILITE® LOFT hood lining
- Supplied with waterproof roll-top stuff-sack and storage cube

Fill Weight: 1478g / 3lb 4oz

Total Weight: \_\_\_\_\_ g / \_\_\_\_\_ oz

Std Pack Size: 34cm x 29cm x 25cm

Bag Fit: Wmns Regular & Wmns Long

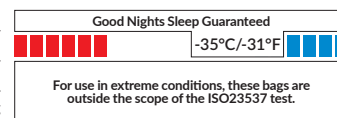

NEW

Regular - ME-006770  
Long - ME-006771

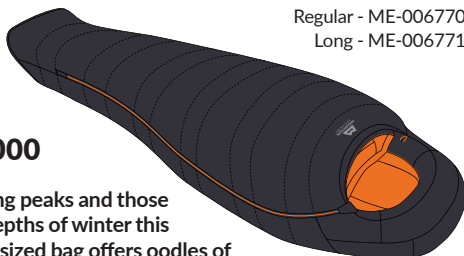

## GLACIER 1000

For higher trekking peaks and those camping in the depths of winter this more generously sized bag offers oodles of warmth and protection.

- DRILITE® LOFT outer shell is lightweight, breathable and water resistant
- 1000g of 90-10 Pure Duck Down with a minimum fill power of 700
- Alpine fit is both spacious and thermally efficient
- Trapezoid baffles and slanted box-wall baffles
- Mid-level side seams
- 5 baffle anatomically shaped hood
- 6 baffle anatomically shaped and offset foot-box
- Full length Gemini zip baffle with 140cm zip and integrated collar with Lode Lock closure
- DRILITE® LOFT hood lining
- Supplied with waterproof roll-top stuff-sack and storage cube

Fill Weight: 1000g / 2lb 3oz

Total Weight: 1580g / 3lb 7.7oz

Std Pack Size: 31cm x 27cm x 23cm

Bag Fit: Regular & Long



NEW

Regular - ME-006772  
Long - ME-006773

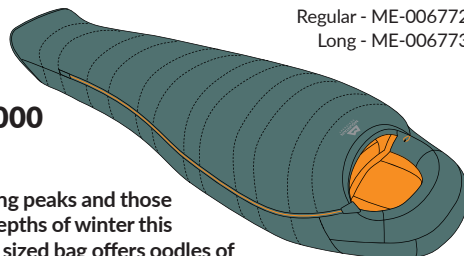

## GLACIER 1000 WOMEN'S

For higher trekking peaks and those camping in the depths of winter this more generously sized bag offers oodles of warmth and protection.

- DRILITE® LOFT outer shell is lightweight, breathable and water resistant
- 950g of 90-10 Pure Duck Down with a minimum fill power of 700
- Women's Alpine fit with zoned EXL system is both spacious and thermally efficient
- Trapezoid baffles and slanted box-wall baffles
- Mid-level side seams
- 5 baffle anatomically shaped hood
- 6 baffle anatomically shaped and offset foot-box
- Full length Gemini zip baffle with 140cm zip and integrated collar with Lode Lock closure
- DRILITE® LOFT hood lining
- Supplied with waterproof roll-top stuff-sack and storage cube

Fill Weight: 950g / 2lb 2oz

Total Weight: \_\_\_\_\_ g / \_\_\_\_\_ oz

Std Pack Size: 30cm x 26cm x 23cm

Bag Fit: Wmns Regular & Wmns Long

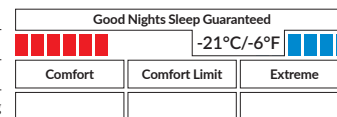

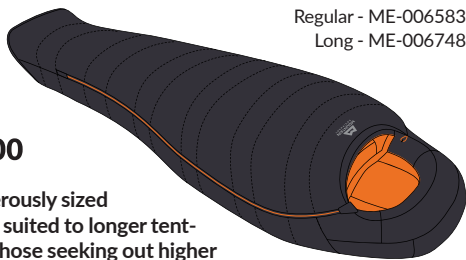

NEW

Regular - ME-006583  
Long - ME-006748

## GLACIER 700

A warm and generously sized sleeping bag well suited to longer tent-based treks and those seeking out higher Himalayan passes.

- DRILITE® LOFT outer shell is lightweight, breathable and water resistant
- 699g of 90-10 Pure Duck Down with a minimum fill power of 700
- Alpine fit is both spacious and thermally efficient
- Trapezoid baffles and slanted box-wall baffles
- Mid-level side seams
- 5 baffle anatomically shaped hood
- 6 baffle anatomically shaped and offset foot-box
- Full length Gemini zip baffle with 140cm zip and integrated collar with Lode Lock closure
- DRILITE® LOFT hood lining
- Supplied with waterproof roll-top stuff-sack and storage cube

Fill Weight: 699g / 1lb 9oz

Total Weight: 1230g / 2 lbs 11 oz

Std Pack Size: 30cm x 22cm x 20cm

Bag Fit: Regular &amp; Long

Good Nights Sleep Guaranteed		
-15°C/5°F		
Comfort	Comfort Limit	Extreme

NEW

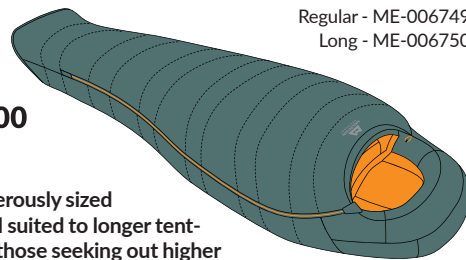
Regular - ME-006749  
Long - ME-006750

## GLACIER 700 WOMEN'S

A warm and generously sized sleeping bag well suited to longer tent-based treks and those seeking out higher Himalayan passes.

- DRILITE® LOFT outer shell is lightweight, breathable and water resistant
- 667g of 90-10 Pure Duck Down with a minimum fill power of 700
- Women's Alpine fit with zoned EXL system is both spacious and thermally efficient
- Trapezoid baffles and Slanted box-wall baffles
- Mid-level side seams
- 5 baffle anatomically shaped hood
- 6 baffle anatomically shaped and offset foot-box
- Full length Gemini zip baffle with 140cm zip and integrated collar with Lode Lock closure
- DRILITE® LOFT hood lining
- Supplied with waterproof roll-top stuff-sack and storage cube

Fill Weight: 667g / 1lb 8oz

Total Weight: 1190g / 2lb 10oz

Std Pack Size: 30cm x 20cm x 20cm

Bag Fit: Wmns Regular &amp; Wmns Long

Good Nights Sleep Guaranteed		
-13°C/9°F		
Comfort	Comfort Limit	Extreme

NEW

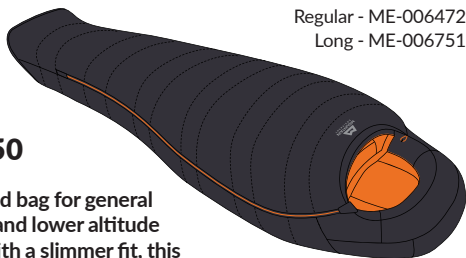
Regular - ME-006472  
Long - ME-006751

## GLACIER 450

A superb all-round bag for general mountaineering and lower altitude trekking trips. With a slimmer fit, this protective bag is ideal for those looking to reduce weight.

- DRILITE® LOFT outer shell is lightweight, breathable and water resistant
- 465g of 90-10 Pure Duck Down with a minimum fill power of 700
- Alpine fit is both spacious and thermally efficient
- Trapezoid baffles and Slanted box-wall baffles
- Mid-level side seams
- 5 baffle anatomically shaped hood
- 6 baffle anatomically shaped and offset foot-box
- Full length Gemini zip baffle with 140cm zip and integrated collar with Lode Lock closure
- DRILITE® LOFT hood lining
- Supplied with waterproof roll-top stuff-sack and storage cube

Fill Weight: 465g / 1lb

Total Weight: 1010g / 2 lbs 4 oz

Std Pack Size: 25cm x 20cm x 17cm

Bag Fit: Regular &amp; Long

Good Nights Sleep Guaranteed		
-9°C/16°F		
Comfort	Comfort Limit	Extreme

NEW

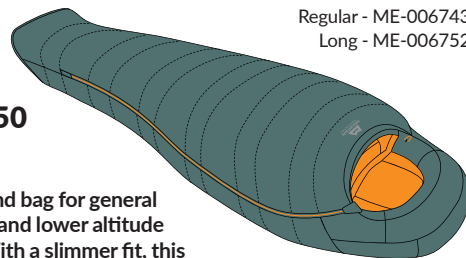
Regular - ME-006743  
Long - ME-006752

## GLACIER 450 WOMEN'S

A superb all-round bag for general mountaineering and lower altitude trekking trips. With a slimmer fit, this protective bag is ideal for those looking to reduce weight.

- DRILITE® LOFT outer shell is lightweight, breathable and water resistant
- 435g of 90-10 Pure Duck Down with a minimum fill power of 700
- Women's Alpine fit with zoned EXL system is both spacious and thermally efficient
- Trapezoid baffles and Slanted box-wall baffles
- Mid-level side seams
- 5 baffle anatomically shaped hood
- 6 baffle anatomically shaped and offset foot-box
- Full length Gemini zip baffle with 140cm zip and integrated collar with Lode Lock closure
- DRILITE® LOFT hood lining
- Supplied with waterproof roll-top stuff-sack and storage cube

Fill Weight: 435g / 15oz

Total Weight: 950g / 2 lbs 2 oz

Std Pack Size: 25cm x 19cm x 17cm

Bag Fit: Wmns Regular &amp; Wmns Long

Good Nights Sleep Guaranteed		
-8°C/18°F		
Comfort	Comfort Limit	Extreme

NEW

Regular - ME-006754  
Long - ME-006755

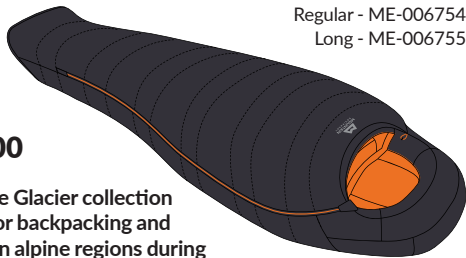

### GLACIER 300

The lightest of the Glacier collection and a great bag for backpacking and mountaineering in alpine regions during the summer months.

- DRILITE® LOFT outer shell is lightweight, breathable and water resistant
- 296g of 90-10 Pure Duck Down with a minimum fill power of 700
- Alpine fit is both spacious and thermally efficient
- Trapezoid baffles and Slanted box-wall baffles
- Mid-level side seams
- 5 baffle anatomically shaped hood
- 6 baffle anatomically shaped and offset foot-box
- Full length Gemini zip baffle with 140cm zip and integrated collar with Lode Lock closure
- DRILITE® LOFT hood lining
- Supplied with waterproof roll-top stuff-sack and storage cube

Fill Weight: 296g / 10oz	Good Nights Sleep Guaranteed		
Total Weight: 870g / 1 lbs 15 oz	-1°C/30°F		
Std Pack Size: 23cm x 18cm x 15cm	Comfort	Comfort Limit	Extreme
Bag Fit: Regular & Long			

NEW

Regular - ME-006756  
Long - ME-006757

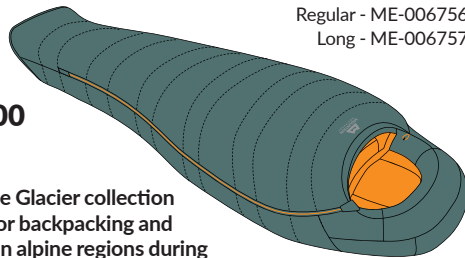

### GLACIER 300 WOMEN'S

The lightest of the Glacier collection and a great bag for backpacking and mountaineering in alpine regions during the summer months.

- DRILITE® LOFT outer shell is lightweight, breathable and water resistant
- 272g of 90-10 Pure Duck Down with a minimum fill power of 700
- Women's Alpine fit with zoned EXL system is both spacious and thermally efficient
- Trapezoid baffles and Slanted box-wall baffles
- Mid-level side seams
- 5 baffle anatomically shaped hood
- 6 baffle anatomically shaped and offset foot-box
- Full length Gemini zip baffle with 140cm zip and integrated collar with Lode Lock closure
- DRILITE® LOFT hood lining
- Supplied with waterproof roll-top stuff-sack and storage cube

Fill Weight: 272g / 10oz	Good Nights Sleep Guaranteed		
Total Weight: _____g / _____oz	-1°C/30°F		
Std Pack Size: 22cm x 18cm x 14cm	Comfort	Comfort Limit	Extreme
Bag Fit: Wmns Regular & Wmns Long			



# HELIUM

---

Enthusiasing the Alpinist's spirit, the Helium range of bags blend craft with function in an otherwise remarkably simple package. Now made from PFC-Free and 100% recycled fabrics the Helium range also benefits from a new more comfortable, yet technical Alpine 2.0 fit and revised collar in selected models. These bags continue to offer class-leading levels of design and functionality and will keep you warm whether hiking a long distance trail or on a Himalayan trek.

---





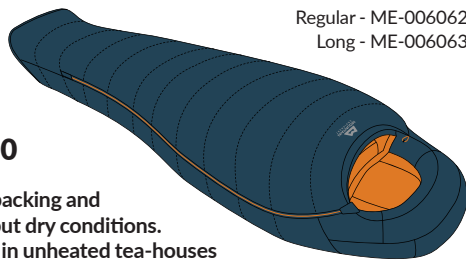

Regular - ME-006062  
Long - ME-006063

## HELIUM 800

Perfect for backpacking and trekking in cold but dry conditions. Whether staying in unheated tea-houses in the Himalaya or winter rooms in the Alps this warm but lightweight bag is the ideal choice.

- 100% recycled HELIUM 20D outer shell is very light and highly breathable with PFC free DWR
- 795g of 90-10 Pure Duck Down with a minimum fill power of 700
- Alpine Fit improves comfort and maximises thermal efficiency
- Slanted box-wall baffles throughout
- Mid-level side seams
- 5 baffle anatomically shaped hood
- 4 baffle anatomically shaped and offset foot-box
- Full length Gemini zip baffle with 140cm zip and integrated neck collar with Lode Lock closure
- 100% recycled Supersoft 20D lining with PFC free DWR
- Supplied with waterproof roll-top stuff-sack and storage cube

Fill Weight: 795g / 1lb 12oz	Good Nights Sleep Guaranteed		
Total Weight: 1230g / 2lb 11.4oz	-16°C/3°F		
Std Pack Size: 31cm x 24cm x 24cm	Comfort	Comfort Limit	Extreme
Bag Fit: Regular & Long	-8°C/18°F	-15°C/5°F	-36°C/-33°F

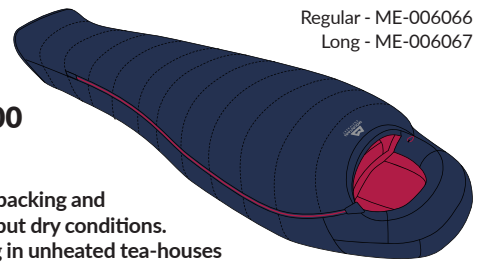

Regular - ME-006066  
Long - ME-006067

## HELIUM 800 WOMEN'S

Perfect for backpacking and trekking in cold but dry conditions. Whether staying in unheated tea-houses in the Himalaya or winter rooms in the Alps this warm but lightweight bag is the ideal choice.

- 100% recycled HELIUM 20D outer shell is very light and highly breathable with PFC free DWR
- 734g of 90-10 Pure Duck Down with a minimum fill power of 700
- Women's Alpine Fit with zoned EXL system maximises thermal efficiency
- Slanted box-wall baffles throughout
- Mid-level side seams
- 5 baffle anatomically shaped hood
- 4 baffle anatomically shaped and offset foot-box
- Full length Gemini zip baffle with 140cm zip and integrated neck collar with Lode Lock closure
- 100% recycled Supersoft 20D lining with PFC free DWR
- Supplied with waterproof roll-top stuff-sack and storage cube

Fill Weight: 734g / 1lb 10oz	Good Nights Sleep Guaranteed		
Total Weight: 1140g / 2lb 8.2oz	-13°C/9°F		
Std Pack Size: 30cm x 24cm x 23cm	Comfort	Comfort Limit	Extreme
Bag Fit: Wmns Regular & Wmns Long	-8°C/18°F	-15°C/5°F	-36°C/-33°F

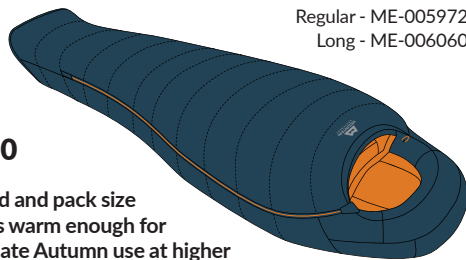

Regular - ME-005972  
Long - ME-006060

## HELIUM 600

Low in weight and and pack size this is a bag that's warm enough for early Spring and late Autumn use at higher altitudes or Northern latitudes.

- 100% recycled HELIUM 20D outer shell is very light and highly breathable with PFC free DWR
- 620g of 90-10 Pure Duck Down with a minimum fill power of 700
- Alpine Fit improves comfort and maximises thermal efficiency
- Slanted box-wall baffles throughout
- Mid-level side seams
- 5 baffle anatomically shaped hood
- 4 baffle anatomically shaped and offset foot-box
- Full length Gemini zip baffle with 140cm zip and integrated neck collar with Lode Lock closure
- 100% recycled Supersoft 20D lining with PFC free DWR
- Supplied with waterproof roll-top stuff-sack and storage cube

Fill Weight: 620g / 1lb 6oz	Good Nights Sleep Guaranteed		
Total Weight: 1030g / 2lb 4.3oz	-10°C/14°F		
Std Pack Size: 25cm x 23cm x 20cm	Comfort	Comfort Limit	Extreme
Bag Fit: Regular & Long	-5°C/23°F	-11°C/12°F	-31°C/-24°F

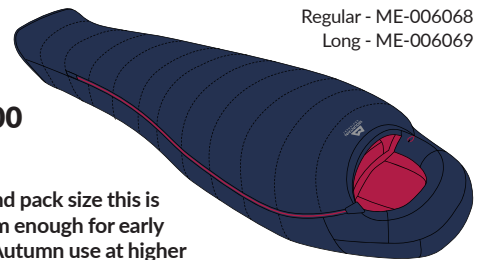

Regular - ME-006068  
Long - ME-006069

## HELIUM 600 WOMEN'S

Low in weight and pack size this is a bag that's warm enough for early Spring and late Autumn use at higher altitudes or Northern latitudes.

- 100% recycled HELIUM 20D outer shell is very light and highly breathable with PFC free DWR
- 554g of 90-10 Pure Duck Down with a minimum fill power of 700
- Women's Alpine Fit with zoned EXL system maximises thermal efficiency
- Slanted box-wall baffles throughout
- Mid-level side seams
- 5 baffle anatomically shaped hood
- 4 baffle anatomically shaped and offset foot-box
- Full length Gemini zip baffle with 140cm zip and integrated neck collar with Lode Lock closure
- 100% recycled Supersoft 20D lining with PFC free DWR
- Supplied with waterproof roll-top stuff-sack and storage cube

Fill Weight: 554g / 1lb 4oz	Good Nights Sleep Guaranteed		
Total Weight: 950g / 2lb 1.5oz	-8°C/18°F		
Std Pack Size: 23cm x 22cm x 22cm	Comfort	Comfort Limit	Extreme
Bag Fit: Wmns Regular & Wmns Long	-5°C/23°F	-11°C/12°F	-31°C/-24°F

Regular - ME-005968  
Long - ME-006058

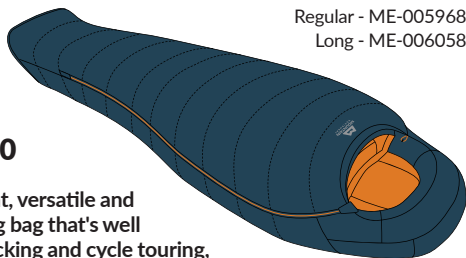

## HELIUM 400

An incredibly light, versatile and packable sleeping bag that's well suited to backpacking and cycle touring, it will still happily cope with cooler nights during the spring and summer months.

- 100% recycled HELIUM 20D outer shell is very light and highly breathable with PFC free DWR
- 403g of 90-10 Pure Duck Down with a minimum fill power of 700
- Alpine Fit improves comfort and maximises thermal efficiency
- Slanted box-wall baffles throughout
- Mid-level side seams
- 5 baffle anatomically shaped hood
- 4 baffle anatomically shaped and offset foot-box
- Full length Gemini zip baffle with 140cm zip and integrated neck collar with Lode Lock closure
- 100% recycled Supersoft 20D lining with PFC free DWR
- Supplied with waterproof roll-top stuff-sack and storage cube

Fill Weight: 403g / 14oz	Good Nights Sleep Guaranteed		
Total Weight: 820g / 1lb 12.9oz	-5°C/23°F		
Std Pack Size: 24cm x 21cm x 20cm	Comfort	Comfort Limit	Extreme
Bag Fit: Regular & Long	0°C/32°F	-6°C/21°F	-24°C/-11°F

Regular - ME-006070  
Long - ME-006071

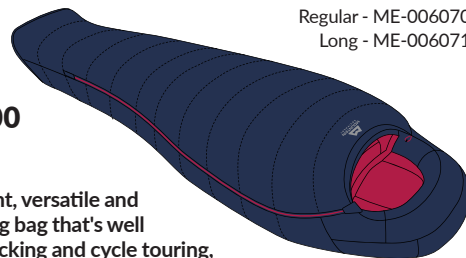

## HELIUM 400 WOMEN'S

An incredibly light, versatile and packable sleeping bag that's well suited to backpacking and cycle touring, it will still happily cope with cooler nights during the spring and summer months.

- 100% recycled HELIUM 20D outer shell is very light and highly breathable with PFC free DWR
- 368g of 90-10 Pure Duck Down with a minimum fill power of 700
- Women's Alpine Fit with zoned EXL system maximises thermal efficiency
- Slanted box-wall baffles throughout
- Mid-level side seams
- 5 baffle anatomically shaped hood
- 4 baffle anatomically shaped and offset foot-box
- Full length Gemini zip baffle with 140cm zip and integrated neck collar with Lode Lock closure
- 100% recycled Supersoft 20D lining with PFC free DWR
- Supplied with waterproof roll-top stuff-sack and storage cube

Fill Weight: 368g / 13oz	Good Nights Sleep Guaranteed		
Total Weight: 750g / 1lb 10.5oz	-3°C/27°F		
Std Pack Size: 20cm x 19cm x 22cm	Comfort	Comfort Limit	Extreme
Bag Fit: Wmns Regular & Wmns Long	0°C/32°F	-6°C/21°F	-24°C/-11°F

Regular - ME-006072  
Long - ME-006073

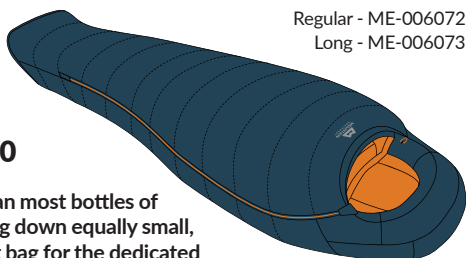

## HELIUM 250

Weighing less than most bottles of water and packing down equally small, this is the perfect bag for the dedicated warm weather backpacker looking to lighten their load.

- 100% recycled HELIUM 20D outer shell is very light and highly breathable with PFC free DWR
- 261g of 90-10 Pure Duck Down with a minimum fill power of 700
- Alpine Fit improves comfort and maximises thermal efficiency
- Slanted box-wall baffles and stitch-through baffles
- Mid-level side seams
- 5 baffle anatomically shaped hood
- 4 baffle anatomically shaped and offset foot-box
- Full length Gemini zip baffle with 140cm zip and integrated neck collar with Lode Lock closure
- 100% recycled Supersoft 20D lining with PFC free DWR
- Supplied with waterproof roll-top stuff-sack and storage cube

Fill Weight: 261g / 9oz	Good Nights Sleep Guaranteed		
Total Weight: 660g / 1lb 7.3oz	1°C/34°F		
Std Pack Size: 19cm x 17cm x 15cm	Comfort	Comfort Limit	Extreme
Bag Fit: Regular & Long	7°C/45°F	2°C/36°F	-12°C/10°F

Regular - ME-006074  
Long - ME-006075

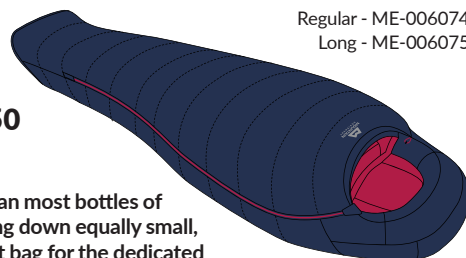

## HELIUM 250 WOMEN'S

Weighing less than most bottles of water and packing down equally small, this is the perfect bag for the dedicated warm weather backpacker looking to lighten their load.

- 100% recycled HELIUM 20D outer shell is very light and highly breathable with PFC free DWR
- 242g of 90-10 Pure Duck Down with a minimum fill power of 700
- Women's Alpine Fit with zoned EXL system maximises thermal efficiency
- Slanted box-wall baffles and stitch-through baffles
- Mid-level side seams
- 5 baffle anatomically shaped hood
- 4 baffle anatomically shaped and offset foot-box
- Full length Gemini zip baffle with 140cm zip and integrated neck collar with Lode Lock closure
- 100% recycled Supersoft 20D lining with PFC free DWR
- Supplied with waterproof roll-top stuff-sack and storage cube

Fill Weight: 242g / 9oz	Good Nights Sleep Guaranteed		
Total Weight: 600g / 1lb 5.2oz	3°C/37°F		
Std Pack Size: 19cm x 17cm x 15cm	Comfort	Comfort Limit	Extreme
Bag Fit: Wmns Regular & Wmns Long	7°C/45°F	2°C/36°F	-12°C/10°F

Regular - ME-006078  
Long - ME-006079

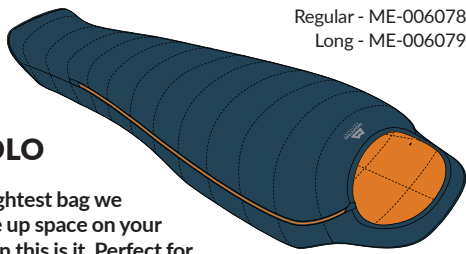

## HELIUM SOLO

If you want the lightest bag we make to help free up space on your global travels then this is it. Perfect for short excursions when a comfortable guest house isn't always guaranteed.

- 100% recycled HELIUM 20D outer shell is very light and highly breathable with PFC free DWR
- 134g of 90-10 Pure Duck Down with a minimum fill power of 700
- Alpine Fit improves comfort and maximises thermal efficiency
- Stitch-through narrow baffle top
- Stitch-through quilted base
- Mid-level side seams
- Shaped hood
- 4 baffle anatomically shaped and offset foot-box
- 100% recycled Supersoft 20D lining with PFC free DWR
- Supplied with lightweight stuff-sack and storage cube

Fill Weight: 134g / 5oz	Good Nights Sleep Guaranteed		
Total Weight: 420g / 14.8oz	7°C/45°F		
Std Pack Size: 22cm x 11cm x 11cm	Comfort	Comfort Limit	Extreme
Bag Fit: Regular & Long	14°C/57°F	10°C/50°F	-1°C/30°F

Regular - ME-006080

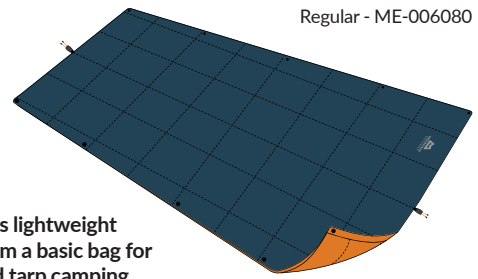

## HELIUM QUILT

Light and totally unrestricted, this lightweight quilt can also form a basic bag for summer tent and tarp camping.

- 100% recycled HELIUM 20D outer shell is very light and highly breathable with PFC free DWR
- 208g of 90-10 Pure Duck Down with a minimum fill power of 700
- Stitch-through quilted construction throughout
- Dual tether drawcords and snap closure top & bottom
- Snap closures along side of quilt
- 100% recycled Supersoft 20D lining with PFC free DWR
- Supplied with lightweight stuff-sack and storage cube
- Dimensions: Length - 203cm/80in  
Width - 150cm/59in  
Foot Width - 120cm/47in

Fill Weight: 208g / 7oz	Good Nights Sleep Guaranteed		
Total Weight: 470g / 1lb .6oz	5°C/40°F		
Std Pack Size: 23cm x 12cm x 12cm	Comfort	Comfort Limit	Extreme
Bag Fit: N/A	N/A	N/A	N/A

ME-006173

## HELIUM EXPANSION BAFFLE

A lightweight expansion baffle providing greater internal space to our down sleeping bags.



- Expands any Helium sleeping bag by 13 cm / 5 inch width
- 2 YKK® zips allow baffle to zip into existing sleeping bag
- 100% recycled HELIUM™ 20 outer shell is very light and highly breathable with PFC free DWR
- 100% recycled Supersoft 20D lining with PFC free DWR
- 30g of 90-10 Pure Duck Down with a minimum fill power of 700
- Supplied with lightweight stuff-sack

\* Not compatible with Helium Solo

\*\*Compatible with all our sleeping bags with 140cm zips



# HELIUM GT

---

Designed for the long-haul and especially comfortable for those who like to sleep on their side as well as on their back, the Helium GT series provides greater comfort and more 'wiggle-room' without sacrificing performance thanks to their significantly more generous yet tapered fit. Made with PFC-Free and 100% recycled fabrics and built with the same feature-set as our standard Helium range, these bags remain highly compressible and reliably warm for extended road trips through the seasons.

---





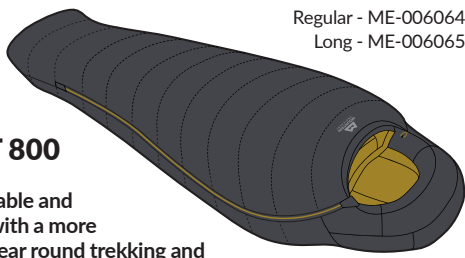

Regular - ME-006064  
Long - ME-006065

## HELIUM GT 800

A warm, comfortable and lightweight bag with a more generous fit for year round trekking and backpacking in cold conditions.

- 100% recycled HELIUM™ 20D outer shell is very light and highly breathable with PFC free DWR
- 844g of 90-10 Pure Duck Down with a minimum fill power of 700
- GT fit is roomy, comfortable and allows for a variety of sleeping positions
- Slanted box-wall baffles throughout
- Mid-level side seams
- 5 baffle anatomically shaped hood
- 4 baffle anatomically shaped and offset foot-box
- Full length Gemini zip baffle with 140cm zip and integrated neck collar with Lode Lock closure
- 100% recycled Supersoft 20D lining fabric with PFC free DWR
- Supplied with waterproof roll-top stuff-sack and storage cube

Fill Weight: 844g / 1lb 14oz	Good Nights Sleep Guaranteed		
Total Weight: 1300g / 2lb 13.9oz	-16°C/3°F		
Std Pack Size: 27cm x 23cm x 22cm	Comfort	Comfort Limit	Extreme
Bag Fit: Regular & Long	-8°C/18°F	-15°C/5°F	-36°C/-33°F

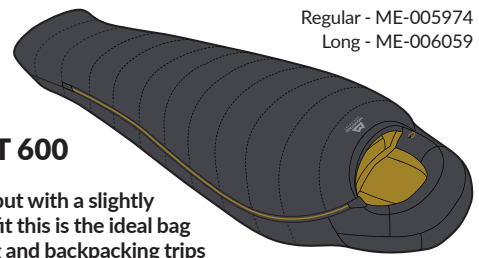

Regular - ME-005974  
Long - ME-006059

## HELIUM GT 600

Light, packable but with a slightly more generous fit this is the ideal bag for long trekking and backpacking trips through Spring and Autumn.

- 100% recycled HELIUM™ 20D outer shell is very light and highly breathable with PFC free DWR
- 656g of 90-10 Pure Duck Down with a minimum fill power of 700
- GT fit is roomy, comfortable and allows for a variety of sleeping positions
- Slanted box-wall baffles throughout
- Mid-level side seams
- 5 baffle anatomically shaped hood
- 4 baffle anatomically shaped and offset foot-box
- Full length Gemini zip baffle with 140cm zip and integrated neck collar with Lode Lock closure
- 100% recycled Supersoft 20D lining fabric with PFC free DWR
- Supplied with waterproof roll-top stuff-sack and storage cube

Fill Weight: 656g / 1lb 7oz	Good Nights Sleep Guaranteed		
Total Weight: 1090g / 2lb 6.4oz	-10°C/14°F		
Std Pack Size: 30cm x 23cm x 23cm	Comfort	Comfort Limit	Extreme
Bag Fit: Regular & Long	-5°C/23°F	-11°C/12°F	-31°C/-24°F

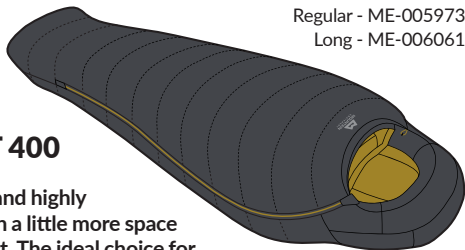

Regular - ME-005973  
Long - ME-006061

## HELIUM GT 400

A light, versatile and highly packable bag with a little more space for added comfort. The ideal choice for backpacking and travelling through summer and cooler Spring nights.

- 100% recycled HELIUM™ 20D outer shell is very light and highly breathable with PFC free DWR
- 449g of 90-10 Pure Duck Down with a minimum fill power of 700
- GT fit is roomy, comfortable and allows for a variety of sleeping positions
- Slanted box-wall baffles throughout
- Mid-level side seams
- 5 baffle anatomically shaped hood
- 4 baffle anatomically shaped and offset foot-box
- Full length Gemini zip baffle with 140cm zip and integrated neck collar with Lode Lock closure
- 100% recycled Supersoft 20D lining fabric with PFC free DWR
- Supplied with waterproof roll-top stuff-sack and storage cube

Fill Weight: 449g / 16oz	Good Nights Sleep Guaranteed		
Total Weight: 890g / 1lb 15.4oz	-5°C/23°F		
Std Pack Size: 24cm x 21cm x 20cm	Comfort	Comfort Limit	Extreme
Bag Fit: Regular & Long	0°C/32°F	-6°C/21°F	-24°C/-11°F

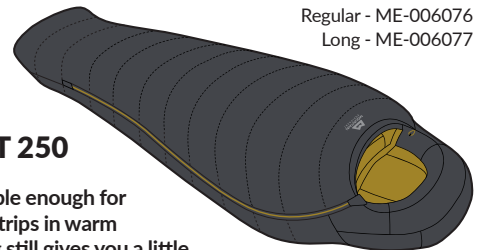

Regular - ME-006076  
Long - ME-006077

## HELIUM GT 250

Light and packable enough for even minimalist trips in warm weather this bag still gives you a little extra room for added comfort.

- 100% recycled HELIUM™ 20D outer shell is very light and highly breathable with PFC free DWR
- 289g of 90-10 Pure Duck Down with a minimum fill power of 700
- GT fit is roomy, comfortable and allows for a variety of sleeping positions
- Slanted box-wall baffles and stitch-through baffles
- Mid-level side seams
- 5 baffle anatomically shaped hood
- 4 baffle anatomically shaped and offset foot-box
- Full length Gemini zip baffle with 140cm zip and integrated neck collar with Lode Lock closure
- 100% recycled Supersoft 20D lining fabric with PFC free DWR
- Supplied with waterproof roll-top stuff-sack and storage cube

Fill Weight: 289g / 10oz	Good Nights Sleep Guaranteed		
Total Weight: 690g / 1lb 8.3oz	1°C/34°F		
Std Pack Size: 22cm x 19cm x 17cm	Comfort	Comfort Limit	Extreme
Bag Fit: Regular & Long	7°C/45°F	2°C/6°F	-12°C/10°F



# OLYMPUS

---

For those taking their first forays into the mountains, the Olympus is an excellent down-filled sleeping bag for those on more modest budgets. It offers a well thought-out and compelling feature-set which includes CODEX® audited down and PFC-Free fabrics. Packing down smaller, weighing less and likely to last far longer than nearly any comparable synthetic bag this is an ideal bag for Spring, Summer and early Autumn.

---

He helium



DOWN 600



## OLYMPUS 450

A perfect first down bag that's ideal for camping and backpacking trips through the warmest months whilst still giving enough insulation for the cooler nights of late Spring and early Autumn.

- HELIUM™ 30D outer shell is light and breathable with PFC free DWR
- 450g of 80-20 Pure Duck Down with a minimum fill power of 600
- Alpine fit 2.0 maximises thermal efficiency
- Slanted box-wall baffles throughout
- Mid-level side seams
- 5 baffle anatomically shaped hood
- 2 baffle anatomically shaped and offset foot-box
- Gemini zip baffle, integrated collar and zipped internal pocket
- Supersoft 30D lining fabric with PFC free DWR
- Supplied with waterproof roll-top stuff-sack and storage cube

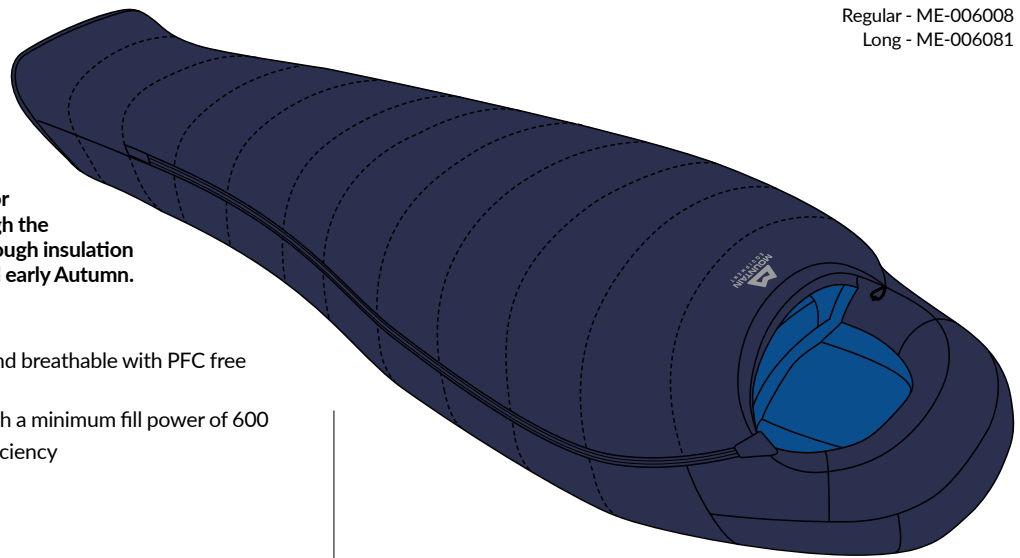

Fill Weight: 450g / 16oz

Total Weight: 940g / 2lb 1.2oz

Std Pack Size: 25cm x 22cm x 21cm

Bag Fit: Regular & Long

Good Nights Sleep Guaranteed		
-5°C/23°F		
Comfort	Comfort Limit	Extreme
1°C/34°F	-5°C/23°F	-22°C/-8°F

## OLYMPUS 450 WOMEN'S

A perfect first down bag that's ideal for camping and backpacking trips through the warmest months whilst still giving enough insulation for the cooler nights of late Spring and early Autumn.

- HELIUM™ 30D outer shell is light and breathable with PFC free DWR
- 456g of 80-20 Pure Duck Down with a minimum fill power of 600
- Women's Alpine fit maximises thermal efficiency
- Slanted box-wall baffles throughout
- Mid-level side seams
- 5 baffle anatomically shaped hood
- 2 baffle anatomically shaped and offset foot-box
- Gemini zip baffle, integrated collar and zipped internal pocket
- Supersoft 30D lining fabric with PFC free DWR
- Supplied with waterproof roll-top stuff-sack and storage cube

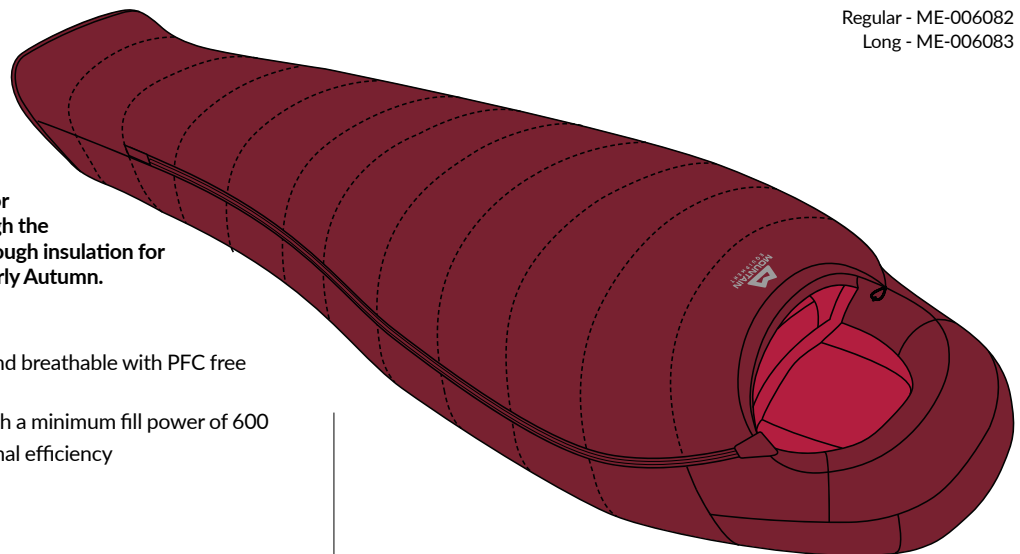

Fill Weight: 456g / 16oz

Total Weight: 920g / 2lb 0.5oz

Std Pack Size: 25cm x 22cm x 21cm

Bag Fit: Wmns Regular & Wmns Long

Good Nights Sleep Guaranteed		
-5°C/23°F		
Comfort	Comfort Limit	Extreme
1°C/34°F	-5°C/23°F	-22°C/-8°F





# Kit Bags & Accessories

Approach to Koyo Zam,  
Pakistan.  
Photography by Usdeem Hawthorn





ME-002739 (40L) - ME-002723 (70L) - ME-002737 (100L) - ME-002738 (140L)

## WET & DRY KIT BAG

A range of robust and versatile kit bags loaded with practical design features.



- Durably waterproof tarpaulin fabric with 1000D Nylon base - as tough as they come
- Nylon webbing reinforced carrying straps and haul handles for multi purpose carrying
- Single padded shoulder strap (40L), padded rucksack straps (70L, 100L & 140L)
- Compression straps
- Large interior mesh pocket and water resistant internal compartment to separate wet and dry items
- Wide U-shaped lid for easy access

	40L	70L	100L	140L
<i>Weight:</i>	1110g / 2lb 7oz	1670g / 3lb 11oz	2160g / 4lb 12oz	2370g / 5lb 4oz
<i>Length:</i>	48cm	67cm	74cm	80cm
<i>Width:</i>	31cm	35cm	41cm	50cm
<i>Height:</i>	28cm	34cm	39cm	42cm
<i>Colour:</i>	ME-01074 - Black / Silver			

ME-002469 (Small) - ME-002468 (Medium) - ME-002466 (Large)

## STORAGE CUBE

Perfect for long-term storage of your down bag, this zip-accessed storage sack will help keep your down sleeping bag in top condition and lofting fully.



- 210D ripstop Nylon top and base with mesh panels
- YKK® reverse coil zip entry
- Cube design is sized per bag and easier to store
- Grab handle for ease of carrying

	SMALL	MEDIUM	LARGE
<i>Weight:</i>	85g / 3oz	95g / 3oz	135g / 4oz
<i>Length:</i>	35cm	38cm	43cm
<i>Width:</i>	35cm	38cm	43cm
<i>Depth:</i>	35cm	38cm	43cm
<i>Colour:</i>	ME-01017 - Vintage Red		





# FITS

The fit of a sleeping bag is crucial in optimising performance. A well-fitting sleeping bag is not only highly comfortable it also reduces dead air space and maximises thermal efficiency. Every Mountain Equipment sleeping bag is specified to one of our unique fits. In turn, bags are then available in either Regular or Long lengths and in Women's specific shape and specification where appropriate.

## Expedition Fit

Wider and marginally longer than our Mountain Fit, the Expedition Fit caters for the needs of high altitude mountaineers and polar explorers who need to wear or store additional items of clothing or even their boots inside their sleeping bag.

Expedition Fit	Regular (cm)	Regular (In)	Long (cm)	Long (In)
Max User Height	185	73	200	79
Length (a)	204	80	219	86
Max Width (b)	80	31	80	31
Inner Foot Width (c)	50	20	50	20

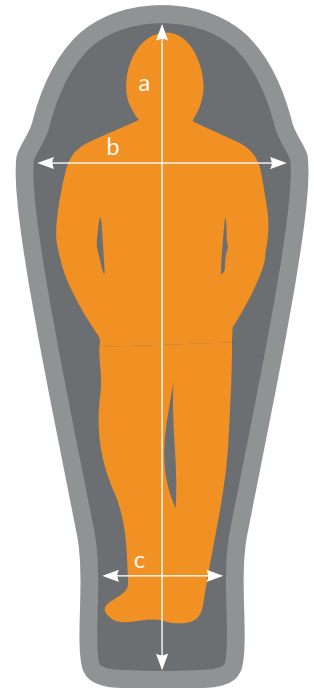

## Alpine Fit

The perfect lightweight sleeping bag shape, offering excellent comfort and usability without adding unnecessary weight.

Alpine Fit - Men's	Regular (cm)	Regular (In)	Long (cm)	Long (In)
Max User Height	185	73	200	79
Length (a)	192	76	207	81
Max Width (b)	78	31	78	31
Inner Foot Width (c)	52	20	52	20

Alpine Fit - Women's	Regular (cm)	Regular (In)	Long (cm)	Long (In)
Max User Height	170	67	185	73
Length (a)	180	71	195	77
Max Width (b)	75	30	75	30
Inner Foot Width (c)	50	20	50	20

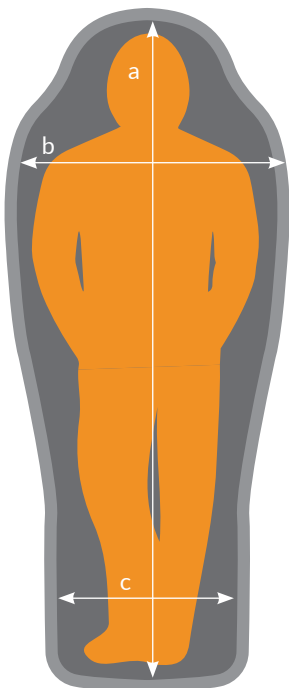



### Mountain Fit

The foundation of all our fit blocks, this semi-tapered mummy profile combines excellent thermal efficiency and comfort for all-round mountain use

Mountain Fit - Men's	Regular (cm)	Regular (In)	Long (cm)	Long (In)
Max User Height	185	73	200	79
Length (a)	190	75	205	81
Max Width (b)	78	31	78	31
Inner Foot Width (c)	50	20	50	20

Mountain Fit - Women's	Regular (cm)	Regular (In)	Long (cm)	Long (In)
Max User Height	170	67	185	73
Length (a)	180	71	195	77
Max Width (b)	78	31	78	31
Inner Foot Width (c)	50	20	50	20

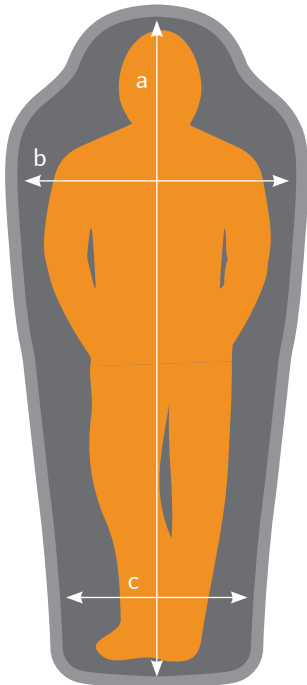
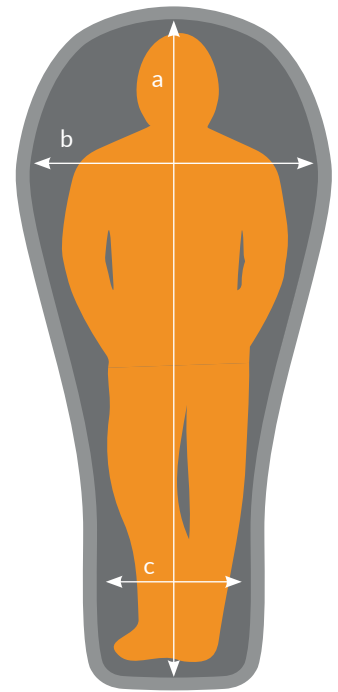

### GT Fit

Our 'Grand Tourer' fit block has greater room at the shoulder, chest and hip than most of our other blocks and is designed to offer maximum comfort, allowing the user to sleep in almost any position.

GT Fit	Regular (cm)	Regular (In)	Long (cm)	Long (In)
Max User Height	185	73	200	79
Length (a)	192	76	207	81
Max Width (b)	82	32	82	32
Inner Foot Width (c)	60	24	60	24

#### Regular:

Designed to fit a maximum user height of 185cm / 6ft 1"

It will perform optimally for those users who are between 178cm and 183cm (5ft 8" and 6ft) in height.

#### Long\*:

Designed to fit a maximum user height of 200cm / 6ft 6"

It will perform optimally for those users who are between 185cm and 197cm (6ft 1" and 6ft 5") in height

#### Regular Women's:

Designed to fit a maximum user height of 170cm / 5ft 6"

It will perform optimally for those users who are between 163cm and 168cm (5ft 3" and 5ft 5") in height.

#### Long Women's\*:

Designed to fit a maximum user height of 185cm / 6ft 1"

It will perform optimally for those users who are between 178cm and 183cm (5ft 8" and 6ft) in height.

\* Some models are only available in Regular or One Size only. Please refer to individual model specifications for details.

# TECHNICAL DATA



## Extreme Expedition

Applicable to: **Redline, Iceline & Snowline**

<b>Fill</b>	90-10 800+ Fill power Goose Down
<b>Shell</b>	GORE-TEX INFINIUM™, 39g/m <sup>2</sup> , 10D Nylon
<b>Lining</b>	Ultrasoft™ 20, 36g/m <sup>2</sup> , 20D Nylon GORE-TEX INFINIUM™, 39g/m <sup>2</sup> , 10D Nylon
<b>Baffle Walls</b>	Mesh Stripping, 50g/m <sup>2</sup> , Nylon
<b>Zip</b>	YKK® #5 Coil 2-way, 140cm
<b>Construction</b>	Ground Level Seams
<b>EXL</b>	Top – Lower Body only
<b>Baffle Type</b>	Vertical V-Baffles Horizontal 14:7 Trapezoid Baffles Side V-Baffle
<b>Footpiece</b>	Trapezium 6 baffle / Bullseye™ / Sharks Toe™
<b>Hood</b>	Down Control 7 baffle with low volume



## Extreme Alpine

Applicable to: **Kryos & Xeros**

<b>Fill</b>	90-10 800+ Fill power Goose Down
<b>Shell</b>	DRILITE® LOFT 10D, 28g/m <sup>2</sup> , 10D Nylon
<b>Lining</b>	Ultrasoft™ 10, 28g/m <sup>2</sup> , 10D Nylon DRILITE® LOFT 10D, 28g/m <sup>2</sup> , 10D Nylon
<b>Baffle Walls</b>	Mesh Stripping, 15g/m <sup>2</sup> , Nylon
<b>Zip</b>	YKK® #5 Coil 2-way, 140cm
<b>Construction</b>	Ground Level Seams
<b>EXL</b>	Top & Bottom – Alternating Baffles
<b>Baffle Type</b>	Horizontal 14:7 Trapezoid Baffles
<b>Footpiece</b>	Trapezium 6 baffle / Bullseye™ / Sharks Toe™
<b>Hood</b>	Down Control 7 baffle with low volume



## Extreme Light

Applicable to: **Fireflash, Firelite & Firefly**

<b>Fill</b>	90-10 900+ Fill power Goose Down
<b>Shell</b>	Plasma™, 26g/m <sup>2</sup> , 10D Nylon with PFC free DWR
<b>Lining</b>	Plasma™, 26g/m <sup>2</sup> , 10D Nylon with PFC free DWR
<b>Baffle Walls</b>	Mesh Stripping, 15g/m <sup>2</sup> , Nylon
<b>Zip</b>	YKK® #5 Coil 2-way, 140cm
<b>Construction</b>	Ground Level Seams
<b>EXL</b>	Top - Main Body
<b>Baffle Type</b>	Slanted Box-Wall Baffles
<b>Footpiece</b>	Trapezium 4 baffle / Bullseye™ / Sharks Toe™
<b>Hood</b>	Down Control 7 baffle with low volume



## Glacier

<b>Fill</b>	90-10 700+ Fill power Duck Down
<b>Shell</b>	DRILITE® LOFT, 55g/m <sup>2</sup> , 30D Nylon
<b>Lining</b>	Supersoft™ 20, 37g/m <sup>2</sup> , 20D 100% Recycled Nylon with PFC free DWR
<b>Baffle Walls</b>	Mesh Stripping, 30g/m <sup>2</sup> , Nylon
<b>Zip</b>	YKK® #5 Coil 2-way, 140cm
<b>Construction</b>	Mid-Level Seams
<b>EXL</b>	Zoned - Women's models only
<b>Baffle Type</b>	Horizontal 15:11 Trapezoid Baffles Slanted Box-Wall Baffles
<b>Footpiece</b>	Trapezium 6 baffle / Bullseye™ / Sharks Toe™
<b>Hood</b>	Down Control 5 baffle



## Helium

<b>Fill</b>	90-10 700+ Fill power Duck Down
<b>Shell</b>	HELIUM™ 20, 34g/m <sup>2</sup> , 20D 100% Recycled Nylon with PFC free DWR
<b>Lining</b>	Supersoft™ 20, 37g/m <sup>2</sup> , 20D 100% Recycled Nylon with PFC free DWR
<b>Baffle Walls</b>	Mesh Stripping, 15g/m <sup>2</sup> , Nylon
<b>Zip</b>	YKK® #5 Coil 2-way, 140cm
<b>Construction</b>	Mid-Level Seams
<b>EXL</b>	Zoned - Women's models only
<b>Baffle Type</b>	Slanted Box-Wall Baffles*
<b>Footpiece</b>	Trapezium 4 baffle / Bullseye™ / Sharks Toe™
<b>Hood</b>	Down Control 5 baffle

\* Helium 250 features Stitch-Through baffles on base  
Excluding Helium Solo and Quilt



## Helium GT

<b>Fill</b>	90-10 700+ Fill power Duck Down
<b>Shell</b>	HELIUM™ 20, 34g/m <sup>2</sup> , 20D 100% Recycled Nylon with PFC free DWR
<b>Lining</b>	Supersoft™ 20, 37g/m <sup>2</sup> , 20D 100% Recycled Nylon with PFC free DWR
<b>Baffle Walls</b>	Mesh Stripping, 15g/m <sup>2</sup> , Nylon
<b>Zip</b>	YKK® #5 Coil 2-way, 140cm
<b>Construction</b>	Mid-Level Seams
<b>EXL</b>	No
<b>Baffle Type</b>	Slanted Box-Wall Baffles
<b>Footpiece</b>	Trapezium 4 baffle / Bullseye™ / Sharks Toe™
<b>Hood</b>	Down Control 5 baffle



Cryophobias,  
North Ghost, Alberta, Canada.  
Photography by Ulstein Howthorn



# OUR GUARANTEES



## Proven technology that guarantees a good night's sleep...

Our sleeping bags have travelled unsupported to both poles, been on every British first ascent of an 8000m peak and been used on well over 100 Everest Expeditions. In fact, every night of the year, somewhere in the world, someone is sleeping comfortably inside a Mountain Equipment sleeping bag. This has resulted in an unsurpassed amount of data and feedback from people experienced in sleeping in real-world conditions, the analysis of which has made today's range of Mountain Equipment sleeping bags our best ever. So confident are we that our sleeping bags will keep you warm and comfortable, in addition to the EN13537 laboratory ratings we quote, you will now see

that every Mountain Equipment sleeping bag comes with a separate 'A Good Night's Sleep Guaranteed' temperature rating.

Resulting from a combination of scientific testing, countless field trials and exhaustive expedition testing, this temperature rating provides an indication as to the minimum temperature that we feel the bag should be comfortable to for an experienced user.

Should you decide that the sleeping bag you've purchased is not as warm as you'd expected it to be we'll upgrade your bag to one of a warmer specification – giving you peace of mind \*

---

\*Valid within 30 days of purchase. It is the responsibility of the customer to return the sleeping bag to the retail store from which it was purchased and to pay any difference in cost between their existing sleeping bag and the one they wish to upgrade to. Due to legal regulations, this additional warranty programme is not available in all territories – please contact your Mountain Equipment representative for more information.

# OUR GUARANTEES



## 10 YEAR GUARANTEE

Mountain Equipment down sleeping bags are designed and manufactured to the highest possible standards, are built to last and should provide you with many years of dependable service.

As such all Mountain Equipment down sleeping bags are fully guaranteed to the original purchaser for 10 years.

Therefore should one of our down sleeping bags fail you due to a defect in components, materials and/or workmanship we will, at our discretion, repair or replace it free of charge.\*\*



## 5 YEAR GUARANTEE

All Mountain Equipment Aerostat mats are fully guaranteed to the original purchaser against defects in materials or workmanship for a period of 5 years.\*\*

Please register your purchase at:  
[www.mountain-equipment.co.uk](http://www.mountain-equipment.co.uk)

\*\*Proof of Purchase required. This guarantee does not cover damage caused by normal wear & tear, misuse use or cover any claims for consequential losses. Nothing contained within this guarantee affects your statutory rights as a consumer that may vary from country to country.

# FAIR WEAR

Together with Fair Wear Foundation, Mountain Equipment are working to achieve fair working conditions in our chosen factories. Mountain Equipment has been a member of FWF since 2012 and has developed a close partnership, first achieving Leader status in 2016.

Mountain Equipment is committed to implementing the strict 8-point FWF Code of Labour Practices, which is based on UN and ILO principles. These include; the payment of living wages, reasonable working hours, safe and healthy working conditions and prevention of child labour.

## We Support



PLAS Y BRENNIN



Front Cover:

Tom Livingstone,  
Pumari Chhish, Pakistan.  
Photography by Muizz Din





# Sales Agents

## Rockies & Southwest, California

Greg Boyd

Boyd and Company LLC

T. 1 (661) 440 4604

E. greg.boyd@oscnainc.com

---

## Pacific Northwest

Rob Scott

Momentum Outdoors Sales LLC

T. 1 (503) 819 1379

E. momentumoutdoor@gmail.com

---

## Mid-Atlantic

Andy Correll

Paul Wu

Dedication Sports

T. 1 (607) 592 0670

T. 1 (781) 820 2517

E. andy.correll@gmail.com

E. paul.w.wu@gmail.com

---

## New England

Dana Seaton

Perspective Outdoor

T. 1 (401) 573 5650

E. dseaton@perspectiveoutdoor.com

---

## North American Office

Outdoor & Sports Company, Inc.

Sales & Marketing Office

T. 1 (905) 940 9511

F. 1 (416) 352 0115

E. sales@oscnainc.com





**MOUNTAIN  
EQUIPMENT**

Outdoor & Sports Company Inc.

104 Crockford Blvd, Unit 216, Scarborough, Ontario, M1R 3C3

T. +1 (905) 940 9511 | F. +1 (416) 352 0115

E. [sales@oscnainc.com](mailto:sales@oscnainc.com) | W. [mountain-equipment.com](http://mountain-equipment.com)

OSC, Inc. is a solely owned subsidiary of Outdoor & Sports Company Holding, Limited, UK.  
Mountain Equipment is a brand of OSC Limited.

---